

PILOT LADDER SAFETY

“DO IT RIGHT, THE FIRST TIME”



<https://pilotladdersafety.com>

Version: July 2021

© Copyright 2020-2021, Herman Broers

**With Quiz to test your
PTA knowledge**

Table of contents

- Foreword 3
- Chapter 1: Pilot Ladder Safety..... 4
- Chapter 2: Securing The Pilot Ladder 11
- Chapter 3: The Steps 17
- Chapter 4: The Ropes 21
- Chapter 5: Combination ladders 23
- Chapter 6: Safe Approach 32
- Chapter 7: Access to Deck 36
- Chapter 8: Handholds and Stanchions 39
- Chapter 9: Pilot Ladder Reels 42
- Chapter 10: Inspection, Maintenance..... 47
- Chapter 11: Marking, Certification..... 50
- Chapter 12: Pilot Ladder Checklist 56
- Reference 57
- Record of changes 57
- Who’s Onboard 58
- Quiz Answers 59

Foreword

During my work as a maritime pilot, many times I encounter badly rigged pilot ladders which do not comply with regulations, guidelines or common-sense seamanship. Looking into this, I discovered there are many things a captain, an officer, or even a bosun, AB or OS has to keep in mind when rigging the ladder. The usability of the documentation in place regarding this matter is not very good. Furthermore, what can be found online are tales of colleagues showing the accidents, the mishaps and the errors they see on a daily basis.

Pilot ladder safety is about a critical operation. For many critical operations onboard there are procedures in place. For the rigging and the use of pilot ladders, often there is nothing in place.

The website pilotladdersafety.com is meant to show the right way to rig and use of the pilot ladder. This document is a hardcopy of the website, and will be updated regularly, as the website changes and improves all the time. Check on the website on a regular basis to check for the latest content. Any changes will be communicated by means of a **newsletter** on a regular basis. If you want to stay up to date all the time, sign up for the newsletter via the website.

If you have feedback or comments about the website or this document, do not hesitate to contact me via info@pilotladdersafety.com

Since the start of the website in July 2020, nearly 200.000 visitors found the website pilotladdersafety.com. This version contains the latest updates of the website until July 1st, 2021.

Rotterdam, July 2021

Herman Broers

Disclaimer:

All information on this document and website is published in good faith and for general information purpose only. Pilotladdersafety.com does not make any warranties about the completeness, reliability and accuracy of this information. Any action you take upon the information you find on this website is strictly at your own risk. We will not be liable for any losses and/or damages in connection with the use of this document / website.

© Copyright Herman Broers, 2020-2021

This Document can be distributed freely for information- and training purposes. Reproduction for commercial- or any other reasons is not allowed unless permitted by the author.

Chapter 1: Pilot Ladder Safety

Pilot Ladder Safety – Do It Right The First Time. Every day around the world, maritime pilots board and disembark ships using pilot ladder arrangements. When the pilot ladder is not used properly, a routine procedure can turn into a critical hazard. There are some very good reasons for using the pilot ladder in the correct way: The safety of the pilot and the structural integrity of the pilot ladder. The aim of this website is to increase Pilot Ladder Safety awareness by showing good practice on the rigging and safe use of the pilot ladder. Through this site, by sharing information, news and feedback about good practice, we can raise the standards of Pilot Ladder Safety – Do It Right The First Time.



A pilot descending a pilot ladder; Pic: Capt. Ed Enos

This website can be used as **an online training tool** to increase mariners', pilots' and maritime professionals' knowledge about the safe use of pilot transfer arrangements (PTA's). Every section of this website ends with a quiz where you can test your knowledge about the section's subject, before moving on to the next section. If you are interested in sharing your ideas or feedback, don't hesitate to contact me on info@pilotladdersafety.com

For every ship there is a different way to rig the ladder properly, due to the nature of its construction. For every ship there is also one way to do it right.

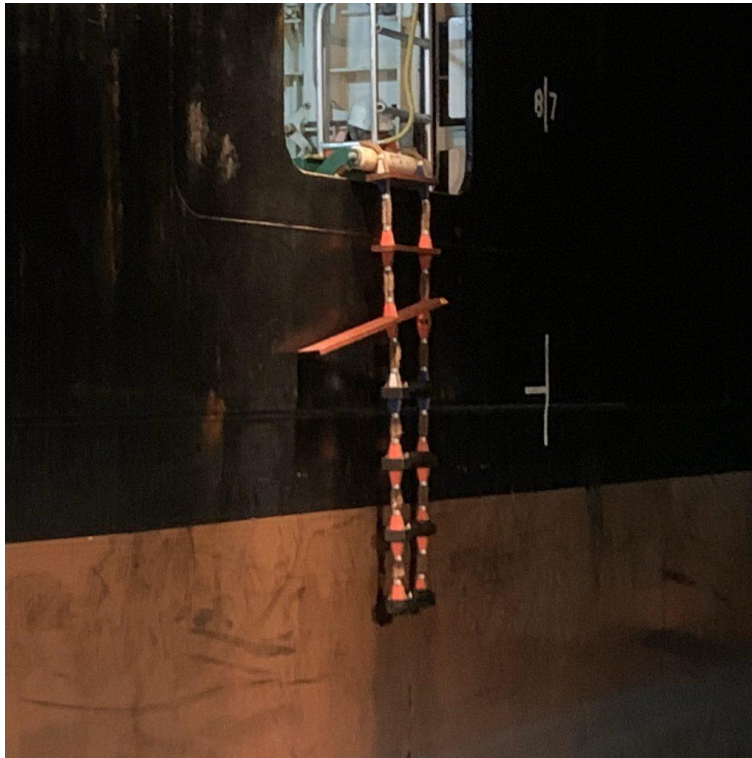

There is a lot that can be improved here

Regulations and guidelines regarding Pilot Ladder safety

1. Solas convention CH V Reg 23 : Regulations regarding Pilot Transfer Arrangements.

The SOLAS Convention in its successive forms is generally regarded as the most important of all international treaties concerning the safety of merchant ships. The first version was adopted in 1914, in response to the Titanic disaster, the second in 1929, the third in 1948, and the fourth in 1960. The 1974 version includes the tacit acceptance procedure – which provides that an amendment shall enter into force on a specified date unless, before that date, objections to the amendment are received from an agreed number of Parties.

As a result the 1974 Convention has been updated and amended on numerous occasions. The Convention in force today is sometimes referred to as SOLAS, 1974, as amended.

Technical provisions:

The main objective of the SOLAS Convention is to specify minimum standards for the construction, equipment and operation of ships, compatible with their safety. Flag States are responsible for ensuring that ships under their flag comply with its requirements, and a number of certificates are prescribed in the Convention as proof that this has been done. Control provisions also allow Contracting Governments to inspect ships of other Contracting States if there are clear grounds for believing that the ship and its equipment do not substantially comply with the requirements of the Convention – this procedure is known as port State control. The current SOLAS Convention includes Articles setting out general obligations,

amendment procedure and so on, followed by an Annex divided into 14 Chapters. (Source: IMO.org)

2. IMO resolution 1045(27). Recommendation on Pilot Transfer Arrangements

These are recommendations covering the technical detail of pilot transfer arrangements which were adopted in November 2011 and replace IMO Resolution A.889(21).

3. ISO 799-1 Ships and marine technology – Pilot ladders – Part 1: Design and specification .

ISO (the International Organization for Standardization) is a worldwide federation of national standards bodies (ISO member bodies). The work of preparing International Standards is normally carried out through ISO technical committees. Each member body interested in a subject for which a technical committee has been established has the right to be represented on that committee. International organizations, governmental and non-governmental, in liaison with ISO, also take part in the work. ISO collaborates closely with the International Electrotechnical Commission (IEC) on all matters of electrotechnical standardization.

This document is intended to supplement existing IMO requirements for pilot ladders. Since IMO instruments do not include specific requirements for prototype testing of pilot ladders for approval, the tests included in this document are in excess of the existing IMO requirements. The reservation and inclusion of these tests was considered necessary in order to provide a means of ensuring conformance of pilot ladders with the performance requirements prescribed in IMO instruments and in this document. This document can be used for independent acceptance of a pilot ladder complying with SOLAS, in which case certification must be issued from a signatory state of SOLAS.

NOTE [ISO 799](#) is incorporated by reference and footnoted in the International Convention on Safety of Life at Sea (SOLAS) Chapter V Regulation 23.2.3.

This document specifies requirements for pilot ladders of a ship, which are provided to enable a maritime pilot to embark and disembark from a ship safely against a vertical portion of the ship's hull. It is applicable to merchant ships which embark and disembark maritime pilots with the ship underway. (Source: Iso.org)

In IMO res 1045 article 1.2, explicit reference is made to ISO Standard 799-1 by means of a footnote.

4. The International Safety Management (ISM) Code:

The purpose of the ISM Code is to provide an international standard for the safe management and operation of ships and for pollution prevention.

The Assembly had already invited all Governments, by resolution A.443(XI), to take the necessary steps to safeguard the shipmaster in the proper discharge of his responsibilities with regard to maritime safety and the protection of the marine environment.

In resolution A.680(17), the Assembly recognized the need for appropriate organization of management to enable it to respond to the need of those on board ships in order to achieve and maintain high standards of safety and environmental protection.

Recognizing that no two shipping companies or shipowners are the same, and that ships operate under a wide range of different conditions, the Code is based on general principles and objectives, which include assessment of all identified risks to one Company's ships, personnel and the environment and establishment of appropriate safeguards.

The Code is expressed in broad terms so that it can have a widespread application. Clearly, different levels of management, whether shore-based or at sea, will require varying levels of knowledge and awareness of the items outlined.

The cornerstone of good safety management is commitment from the top. In matters of safety and environment protection it is the commitment, competence, attitudes and motivation of individuals at all levels that determines the end result.(Source: IMO.org)

1.2.3 The safety-management system should ensure: .1 compliance with mandatory rules and regulations; and .2 that applicable codes, guidelines and standards recommended by the Organization, Administrations, classification societies and maritime industry organizations are taken into account.

Pilot Ladder Safety as a System

Pilot ladder safety is a chain-like system of regulations, recommendations, industry standards and procedures. If any of these links is broken, the safety as a system fails with possible fatal consequences.

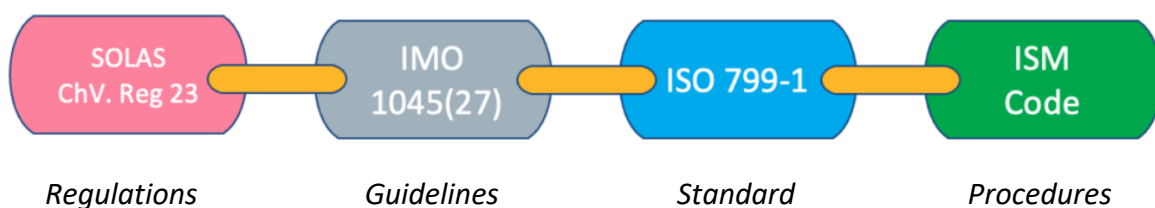

In IMO resolution A.1045(27) RECOMMENDATION ON PILOT TRANSFER ARRANGEMENTS, the first two articles (see below) contain the encouragement for ships designers, equipment designers and manufacturers of pilot ladders to provide the users with means to ensure the overall SOLAS goal of: " All arrangements used for pilot transfer shall efficiently fulfil their purpose of enabling pilots to embark and disembark safely."

Having ensured that the ship's design, the equipment design, as well as the pilot ladders are suitable for the intended purpose, and having a Safety Management System in place as per ISM, the question is why so many incidents still happen with pilot ladders, pilot transfers and non compliant ladders.

That question cannot easily be answered, but a lot has to do with awareness and training. This website is intended to raise the general awareness about pilot ladder safety.

So what's a pilot ladder?

Not every ladder that is rigged overboard is a pilot ladder. In ISO 799-1, the main manufacturing and material requirements for a pilot ladder can be found. A ladder conforming to this standard, shall be designated by the code: "Pilot Ladder ISO 799-1" – S (number of steps) – L (length in meters) “. This should be marked on the bottom spreader and the top step. So when it says "Embarkation Ladder" it is NOT a pilot ladder.

Test your knowledge about this section of the website:

QUIZ 1: Regulatory framework

(Correct answers: see last page of this document)

- 1. Pilot transfer arrangement REGULATIONS can be found in:**
 - A. SOLAS convention Ch.V Reg 23
 - B. IMO 1045(27)
 - C. ISO 799-1
 - D. ISM Code / Safety Management System
- 2. Pilot transfer arrangement GUIDELINES can be found in:**
 - A. SOLAS convention Ch.V Reg 23
 - B. IMO 1045(27)
 - C. ISO 799-1
 - D. ISM Code / Safety Management System
- 3. Pilot transfer arrangement PROCEDURES can be found in:**
 - A. SOLAS convention Ch.V Reg 23
 - B. IMO 1045(27)
 - C. ISO 799-1
 - D. ISM Code / Safety Management System
- 4. Pilot transfer arrangement INDUSTRY STANDARDS can be found in:**
 - A. SOLAS convention Ch.V Reg 23
 - B. IMO 1045(27)
 - C. ISO 799-1
 - D. ISM Code / Safety Management System

For the various pages of this website, the applicable SOLAS requirements are marked in pink.

The applicable IMO 1045(27) resolution recommendations are marked in grey.

The applicable International safety management (ISM)-Code regulations are marked in green.

Solas Ch V Reg 23: General regulations

1. Application

1.1. Ships engaged on voyages in the course of which pilots may be employed shall be provided with pilot transfer arrangements.

1.2. Equipment and arrangements for pilot transfer which are installed on or after 1 July 2012 shall comply with the requirements of this regulation, and due regard shall be paid to the standards adopted by the Organization.

1.3. Except as provided otherwise, equipment and arrangements for pilot transfer which are provided on ships before 1 July 2012 shall at least comply with the requirements of regulation 17 or 23, as applicable, of the International Convention for the Safety of Life at Sea, 1974, in force prior to that date, and due regard shall be paid to the standards adopted by the Organization prior to that date.

1.4. Equipment and arrangements installed on or after 1 July 2012, which are a replacement of equipment and arrangements provided on ships before 1 July 2012, shall, in so far as is reasonable and practicable, comply with the requirements of this regulation.

1.5. With respect to ships constructed before 1 January 1994, paragraph 5 shall apply not later than the first survey on or after 1 July 2012.

1.6. Paragraph 6 applies to all ships.

2. General

2.1. All arrangements used for pilot transfer shall efficiently fulfil their purpose of enabling pilots to embark and disembark safely. The appliances shall be kept clean, properly maintained and stowed and shall be regularly inspected to ensure that they are safe to use. They shall be used solely for the embarkation and disembarkation of personnel.

3. Transfer arrangements

3.1. Arrangements shall be provided to enable the pilot to embark and disembark safely on either side of the ship.

3.2. In all ships, where the distance from sea level to the point of access to, or egress from, the ship exceeds 9 m, and when it is intended to embark and disembark pilots by means of the accommodation ladder, or other equally safe and convenient means in conjunction with a pilot ladder, the ship shall carry such equipment on each side, unless the equipment is capable of being transferred for use on either side.

IMO Resolution A.1045(27)

RECOMMENDATION ON PILOT TRANSFER ARRANGEMENTS

1 GENERAL

Ship designers are encouraged to consider all aspects of pilot transfer arrangements at an early stage in design. Equipment designers and manufacturers are similarly encouraged, particularly with respect to the provisions of paragraphs 2.1.2, 3.1 and 3.3.

2 PILOT LADDERS

A pilot ladder should be certified by the manufacturer as complying with this section or with the requirements of an international standard acceptable to the Organization.¹

2.1 Position and construction

2.1.1 The securing strong points, shackles and securing ropes should be at least as strong as the side ropes specified in section 2.2 below.

Chapter 2: Securing The Pilot Ladder

The securing of the pilot ladder is the most important link in the pilot ladder safety chain.

With all the regulations in place there are no guidelines on how to secure a pilot ladder to the ship. Since many times the pilot ladder cannot be secured at full length, due to the varying freeboard at specific loading conditions, it has to be secured at intermediate length. That can only be done in a safe way when the following conditions are met:

1. The weight of the ladder cannot be transferred to the steps, the spreaders or the chocks, since they are not intended to be used for this purpose.
2. The securing arrangement must be such that no damage is done to the structural integrity of the pilot ladder.

The Pilot Ladder should be secured to the ship's deck, on designated strong points, by means of the ladder's side ropes.

The weight of the ladder must be transferred from ladder's side ropes to the strong point on deck directly. Never use the ladder's steps, spreaders or chocks to carry the weight of the ladder since they are not designed for this and are not strong enough. For this reason, shackles, bars and tongues should never be used to secure the ladder to the deck. They will damage the ladder and put weight on the parts which are not designed to carry the weight.

The easiest way to secure the ladder is the use of two strong (at least 2 x 24 kN) manila ropes directly attached to each side rope of the pilot ladder, by means of a **rolling hitch knot**. This will transfer the weight of the ladder arrangement directly onto the designated strong point and will not damage the ladder in any way.



rolling hitch 1



rolling hitch 2



rolling hitch 3



rolling hitch 4

The ladder should be rigged over the deck edge, in an opening in the ship's railing or over a bulwark. In the latter case a bulwark ladder must be used for safe access. Ideally, the deck edge should be rounded to prevent the cutting or damaging of the pilot ladder's side ropes.

In the next picture, the design and the rigging of the pilot ladder has been done by the book. This ensures 1) a correct weight transfer from the ladder onto the deck, and 2) there is no excessive wear caused by sharp edges or incorrect load on the ladder's parts. In this case the strongpoints have been certified to 4 tons SWL. A top job!



The rolling hitch knot used on a well rigged pilot-ladder arrangement. Observe the marked strong points on deck (SWL 4T) Pic: Cpt. Gary Clay,

Always use a designated strong point to secure the ladder. Never use railings or pipelines since they have no certified strength.

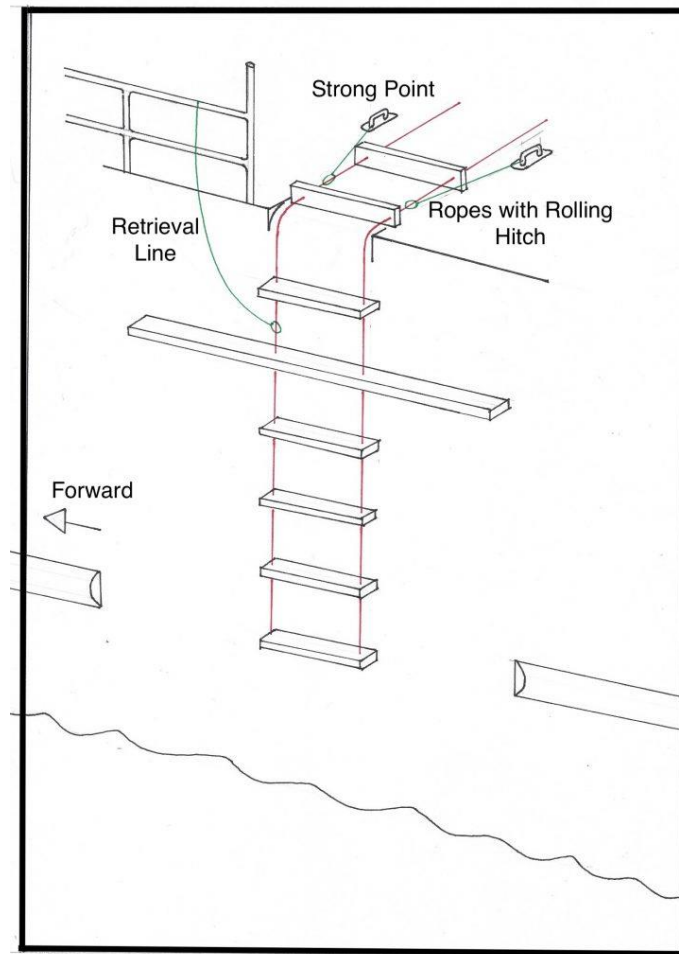

Securing of the Pilot Ladder

From a design point of view there is a lot that can be improved to make the securing of the ladder an easy job

In some cases the design of the Pilot Access Area is so poor that it seems hand railings with sharp edges are the only option to secure the ladder. This will cause damage and wear to the ropes of the ladder.

The following poster is a very clear instruction posted at the pilot boarding area onboard some Maersk vessels. It is an excellent example of good practice and leaves no doubt what a properly secured pilot ladder should look like:

Rigging of Pilot Ladders

When rigging the pilot ladder **DO NOT** use the stanchions to secure the rope ladder.



(This will put all weight on ladder steps and checks which they are not designed to withstand.)

Secure the pilot ladder by using rope stoppers which shall be lashed to the side ropes and attached to strong lashing points on deck

– as shown on this picture.



“Rigging of Pilot Ladders” Instruction found onboard of a Maersk vessel

In the next picture it is clear that the design of the pilot ladder access point sometimes does not allow for the required length of rope to secure the ladder, like in the previous case. There are two eyes, which are only inches away from the rounded edge and therefore useless. In this case, two designated eyes (strong points) should have been welded onto the main deck, preferably at a good distance from the ship's side, well marked and load tested to at least 48 kN each, which is the total MBL (Minimum Breaking Load) of the side ropes.

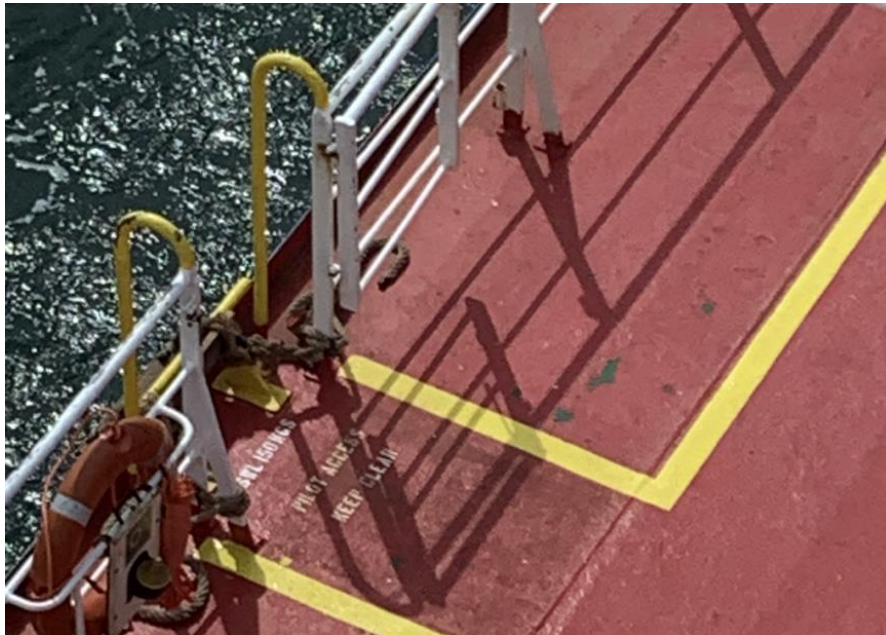

Pilot access area without strong points for securing the ladder

The following pictures show four methods of intermediate securing of pilot ladders which are **not recommended by pilots** for various reasons. (see the description under each picture)

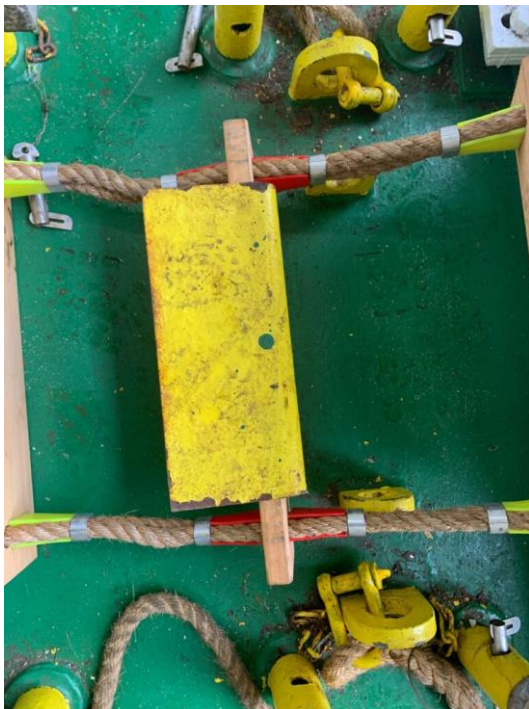

Deck Tongue: all weight rests on the steps

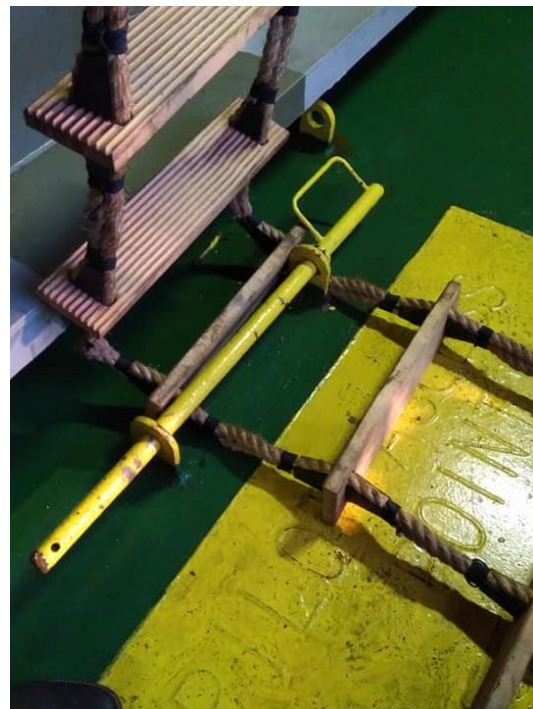

Steel Bar: damaging to the chocks and steps of the ladder



D-S Shackles: damaging to the chocks and steps

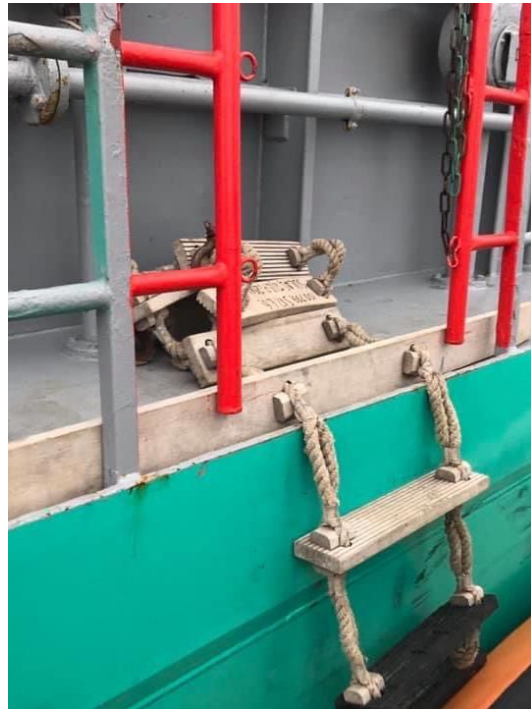

The spreader as a securing device: it is not designed to carry the weight

QUIZ 2: Securing The Pilot Ladder
(Correct answers: see last page of this document)

- 1. There are clear guidelines in SOLAS and IMO 1045(27) on how to secure a pilot ladder at intermediate length**
 - A. True
 - B. Not true
- 2. The steps and spreaders are as strong as the sideropes and can be used to carry the weight of the ladder**
 - A. True
 - B. Not True
- 3. The deck edge should be ...**
 - A. ... sharp to ensure the ladder rests firmly against the ship side
 - B. ... rounded to prevent damage to the ladder's side ropes
 - C. ... fitted with a deck tongue for the steps to rest on
- 4. Identify the methods of intermediate securing which are NOT recommended by pilots (multiple answers possible)**
 - A. Deck Tongue
 - B. Steel Bar
 - C. Rolling Hitch Knot
 - D. D-shackles
 - E. Spreaders

Chapter 3: The Steps

A bad pilot ladder, with worn-out steps and side ropes is not a good welcome sign for a pilot onboard a ship. It is easy to inspect the steps every time the ladder is used. Make sure the steps are in good shape, and clean, ready to use.

The retrieval line is sometimes referred to by pilot as “the trip line”. On a rolling ship it can easily get in the way of the pilot boat fendering or crew, or the pilot climbing the ladder. And there is only one way it should be attached: **At or above the bottom spreader, leading forward**. This also implies that when a combination ladder is used, the retrieval line of the pilot ladder should be rigged underneath the accommodation ladder.



The spreader in action: preventing the twisting of the ladder during its use (Source: facebook group #dangerousladders)

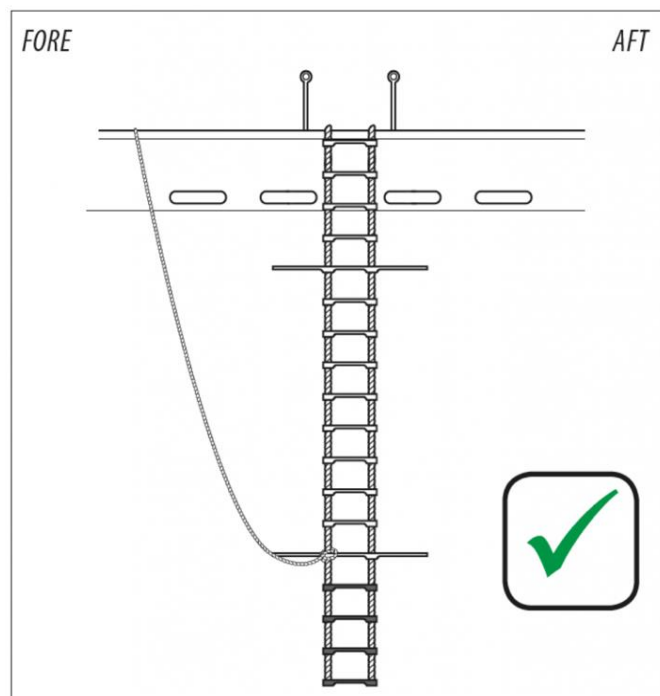

Retrieval line: At or above the spreader, leading forward

When markings are used, they should not be painted on the ladder's steps, paint and varnish make the ladder slippery and therefore dangerous.

As per ISO 799, the following requirements apply to the steps:

1. Steps to be made from hardwood, resilient plastic or rubber
2. If made of wood, they are free of knots and uncoated
3. Steps have a grooved, patterned, or moulded non-skid surface
4. Anti skid adhesive sheeting may not be used
5. Step thickness should be a minimum of 25 mm (excluding the non skid treatment or grooving)
6. The lower four steps shall be made of rubber

7. The fifth step from the bottom shall be a spreader, and from there every 3 meters a spreader shall be fitted, minimum 1.8 m length.
8. Replacement steps shall be provided by the manufacturer only
9. No more than 2 replacement steps can be used

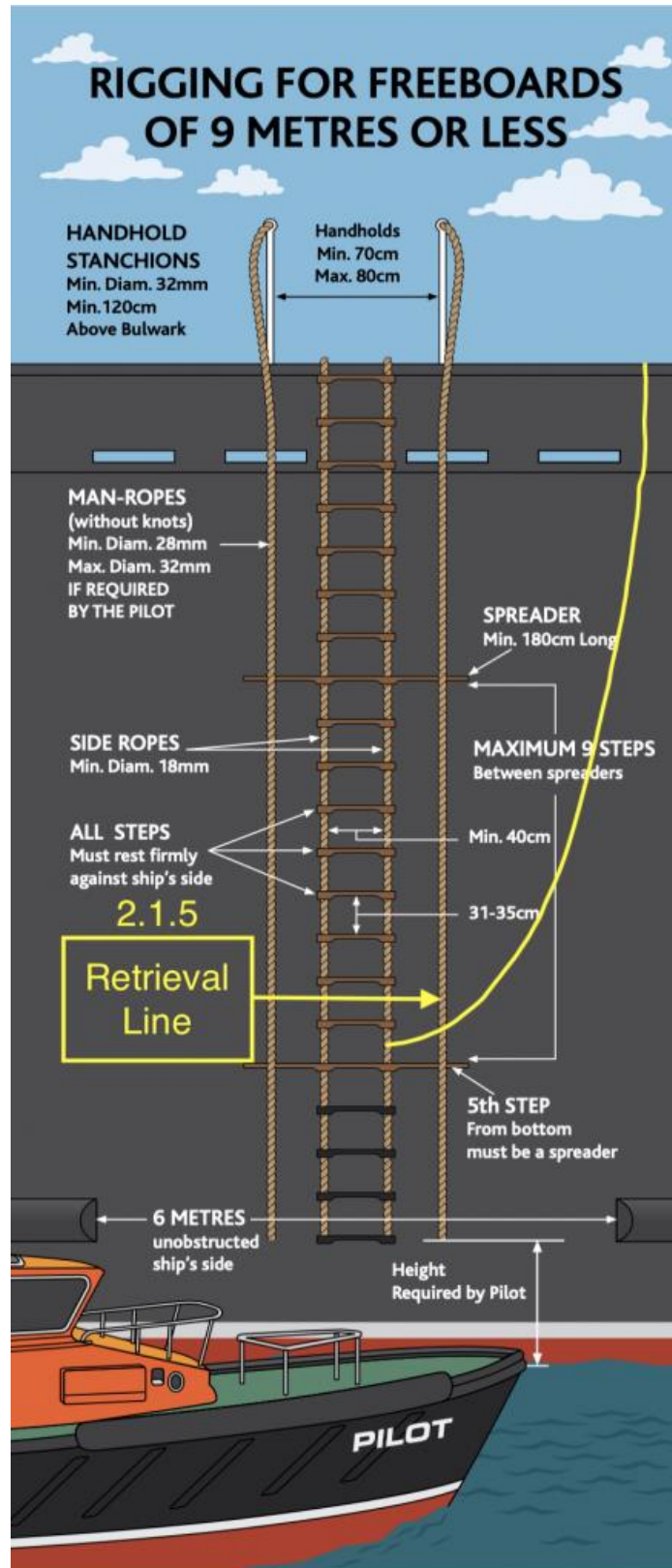

The Steps: Detail of Wheelhouse poster

The arrangement for the bottom step of the ladder can be done in two ways:

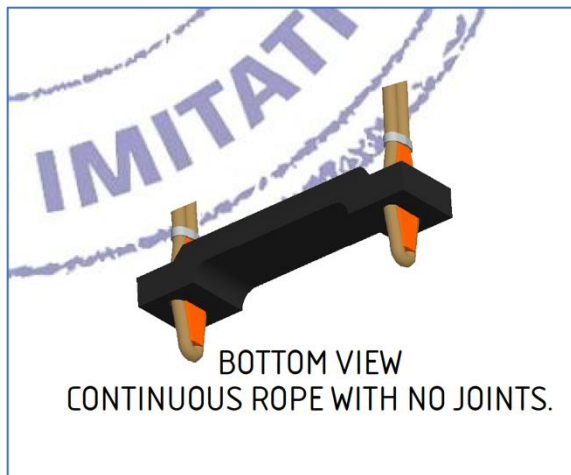

*Continuous Rope with no joints
(Source: PTR Holland)*

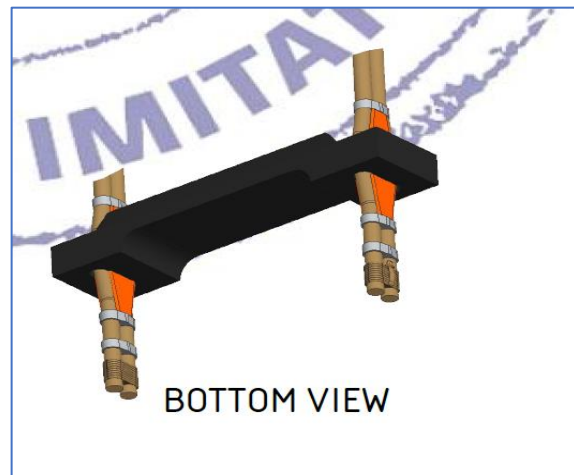

*Side ropes terminate below the bottom step (Source:
PTR Holland)*

In the above picture, there is a continuous rope with no joints. In this arrangement, there still needs to be a chock below the bottom step, in order to prevent the bottom step from twisting.

In case the side ropes terminate below the bottom step, the chock is also needed. The sideropes need to be clamped by two rope seizings or clamps below the chock, and a whipping of at least 25 mm below the lower seizing, to prevent fraying. (source: ISO 799-1)

QUIZ 3: The Steps

(Correct answers: see last page of this document)

1. **The retrieval line, when used should be...**
 - A. Above the lowest spreader, leading aft
 - B. Below the lowest spreader, leading forward
 - C. Above the lowest spreader, leading forward
 - D. Below the lowest spreader, leading aft
2. **The maximum number of replacement steps to be used on a ladder is**
 - A. None
 - B. Two
 - C. Four
 - D. Six
 - E. No limit
3. **The Pilot Ladder steps should be made of**
 - A. Hardwood only
 - B. Hardwood or any other material of equivalent strength, stiffness and durability
 - C. Hardwood and rubber
4. **The function of the spreader is...**
 - A. ... to have an easy marking for the length of the pilot ladder
 - B. ... to provide an extra securing method for the pilot ladder
 - C. ... to make it easier to recover the pilot ladder
 - D. ... to prevent the ladder from twisting on a rolling ship

IMO 1045(27) Pilot Transfer Arrangements

2.1.2 *The steps of the pilot ladders should comply with the following requirements:*

- *if made of hardwood, they should be made in one piece, free of knots;*
- *if made of material other than hardwood, they should be of equivalent strength, stiffness and durability to the satisfaction of the Administration;*
- *the four lowest steps may be of rubber of sufficient strength and stiffness or other material to the satisfaction of the Administration;*
- *they should have an efficient non-slip surface;*
- *they should be not less than 400 mm between the side ropes, 115 mm wide and 25 mm in depth, excluding any non-slip device or grooving;*
- *they should be equally spaced not less than 310 mm or more than 350 mm apart; and*
- *they should be secured in such a manner that each will remain horizontal.*

2.1.3 *No pilot ladder should have more than two replacement steps which are secured in position by a method different from that used in the original construction of the ladder, and any steps so secured should be replaced as soon as reasonably practicable by steps secured in position by the method used in the original construction of the pilot ladder. When any replacement step is secured to the side ropes of the pilot ladder by means of grooves in the sides of the step, such grooves should be in the longer sides of the step.*

2.1.4 *Pilot ladders with more than five steps should have spreader steps not less than 1.8 m long provided at such intervals as will prevent the pilot ladder from twisting. The lowest spreader step should be the fifth step from the bottom of the ladder and the interval between any spreader step and the next should not exceed nine steps.*

2.1.5 *When a retrieval line is considered necessary to ensure the safe rigging of a pilot ladder, the line should be fastened at or above the last spreader step and should lead forward. The retrieval line should not hinder the pilot nor obstruct the safe approach of the pilot boat.*

2.1.6 *A permanent marking should be provided at regular intervals (e.g. 1 m) throughout the length of the ladder consistent with ladder design, use and maintenance in order to facilitate the rigging of the ladder to the required height.*

Chapter 4: The Ropes



The ropes are the strongest part of the pilot ladder. Since the rope material is manilla rope, it is very vulnerable and sensitive to salt and water. Special care should therefore be taken when stowing the pilot ladder during the sea voyage.

As per ISO 799 the following requirements apply to the side ropes:

1. Manilla rope as per ISO 1181:2004 or similar
2. Rope's breaking strength is 24 kN, with a diameter of 20 mm.
3. Metals used for clamping and fastening shall be corrosion resistant
4. The side ropes are continuous loops with the joint above the top step or below the bottom step only.
5. When the ladder is in use, the ropes cannot come in contact with the ship's hull.

The ropes are the strongest parts of the pilot ladder, rated at 24 kN each.

There are 2 double side ropes on each side of the ladder. That makes the total strength 2 x 48 kN. The ropes should be the only part of the ladder to carry the static and dynamic weight of the ladder. These forces should never be transferred to the ship's deck via wooden parts of the ladder, or uncertified strong points on deck, such as railings and pipes. That's why shackles and tongues on deck should not be used to secure the pilot ladder. Use only designated strong points!

The soft material of which the ropes are made requires soft edges in way of the pilot access point over which the pilot ladder is hanging overboard. Once again, this both to enhance safety as well as the ladder's lifespan.

QUIZ 4: The Ropes

(Correct answers: see last page of this document)

1. **The number of ropes on the pilot ladder is:**
 - A. One continuous rope from left to right
 - B. Two lengths of rope, one loop on each side
 - C. Four lengths of rope, two on each side
2. **If two ladders have to be joined together, the preferred securing method is:**
 - A. The rolling hitch knot
 - B. D-shackles
 - C. It is NOT allowed to join ladders together. They should be made of continuous lengths.
3. **The function of chocks or widgets is...**
 - A. To make sure the side rope does not touch the ship's side
 - B. To keep the steps level
 - C. To provide a marking of the pilot ladder's length
 - D. To make it easier to stow the ladder on deck
4. **The best way to protect the ropes from the seawater is...**
 - A. ... to cover the ropes with duct tape or similar to keep them dry all the time
 - B. ... to store the pilot ladder in a dry, well ventilated place when not in use
 - C. ... to store the pilot ladder on deck so the wind and sea water can keep the ropes wet all the time

IMO 1045(27) Pilot Transfer Arrangements:

2.2 Ropes

2.2.1 *The side ropes of the pilot ladder should consist of two uncovered ropes not less than 18 mm in diameter on each side and should be continuous, with no joints and have a breaking strength of at least 24 Kilo Newtons per side rope. The two side ropes should each consist of one continuous length of rope, the midpoint half-length being located on a thimble large enough to accommodate at least two passes of side rope.²*

2.2.2 *Side ropes should be made of manila or other material of equivalent strength, durability, elongation characteristics and grip which has been protected against actinic degradation and is satisfactory to the Administration.*

2.2.3 *Each pair of side ropes should be secured together both above and below each step with a mechanical clamping device properly designed for this purpose, or seizing method with step fixtures (chocks or widgets), which holds each step level when the ladder is hanging freely. The preferred method is seizing.¹*

¹*Refer to the recommendations by the International Organization for Standardization, in particular publication ISO 799:2004, Ships and marine technology — Pilot ladders, part 4.3a and part 3, paragraph 3.2.1.*

Chapter 5: Combination ladders

The use of a combination ladder, an accommodation ladder as well as a pilot ladder, is needed when the freeboard of the ship is more than 9 meters. It is important to allow a free space of more than 5 meters under the platform of the accommodation ladder, to let the pilot boat come alongside safely.

The pilot ladder must extend at least 2 meters above the platform of the accommodation ladder, so that the pilot can safely transfer from the pilot ladder to the platform of the accommodation ladder, vice versa.

The Accommodation ladder and the pilot ladder must be secured to the ship side independent of each other

Since this type of combination ladder is often used on empty tankers, the rolling of the vessel can be considerable. For this reason, it is very important that the pilot ladder, as well as the accommodation ladder are well secured to the ships side, independent of each other. Climbing or descending a pilot ladder which is swinging away from the ship's hull is very dangerous. The securing of the pilot ladder to the ship's hull should be placed 1,5 meters above the platform of the accommodation ladder, one lashing on each side rope.

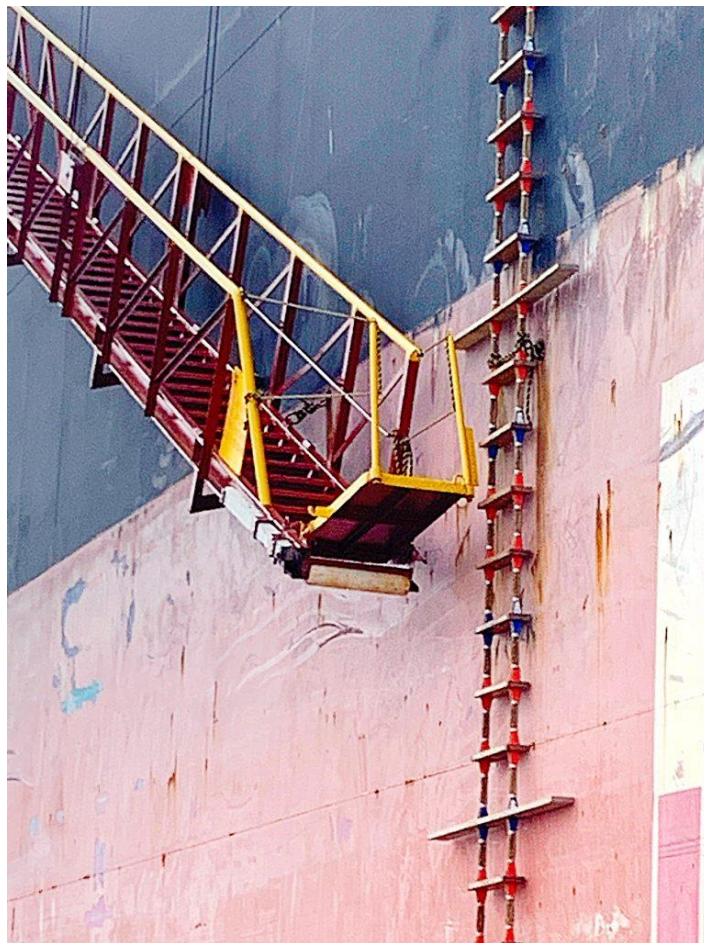

A well secured combination pilot ladder

In the previous picture, the inner stanchion on the bottom platform is rigged in place, as it should be. The below two pictures show what happens when the inner stanchion is not used: on the final step of his descend onto the platform, he has only one hand to hold his balance. That could be fatal when the ship takes a sudden roll. Always secure the inner stanchion in place.



On the final step to the platform and onto the pilot ladder, the pilot has only one hand to hold himself if the inboard stanchion is not in place. (Source: Sea and Coast Magazine, via Facebook)



pic: Capt Sam Stephenson, J.D. via LinkedIn

In the next picture (left), the pilot embarks a vessel using a combination ladder. The first thing he grabs when he steps off the pilot ladder onto the accommodation ladder is the inner stanchion. It is the closest to the pilot ladder and that's why it is very important for getting balance when stepping onto the platform.

On the IMO's Wheelhouse poster, all important information is given on the correct rigging and dimensions of a combination ladder.

COMBINATION ARRANGEMENT FOR SHIPS WITH A FREEBOARD OF MORE THAN 9 METRES WHEN NO SIDE DOOR AVAILABLE

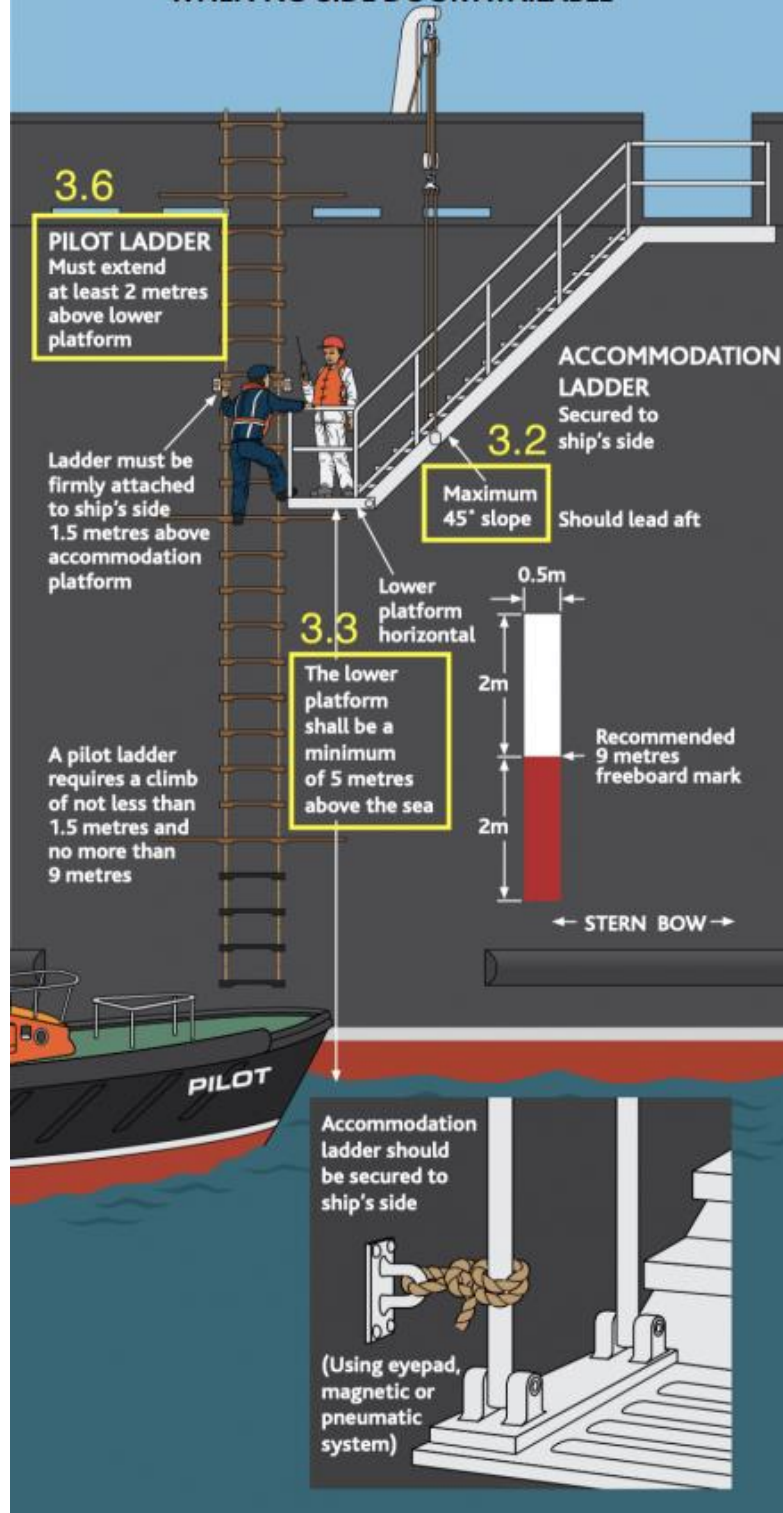

Combination Ladders; Detail of Wheelhouse poster

Trapdoor arrangement

One very special kind of combination ladder arrangement is the so-called trapdoor arrangement.

Many pilots do not like to use this system, because it requires a lot of acrobatics to embark or disembark the ship. In december 2019 a New York pilot died when boarding a ship with this system, which attracted a lot of **attention in the press**.

SOLAS regulations are very clear about this type of arrangement:

” In the case of a combination arrangement using an accommodation ladder with a trapdoor in the bottom platform (i.e. embarkation platform), the pilot ladder and man ropes shall be rigged through the trapdoor extending above the platform to the height of the handrail.”

This clearly makes many trapdoor arrangements, such as the one in the below picture non-compliant.

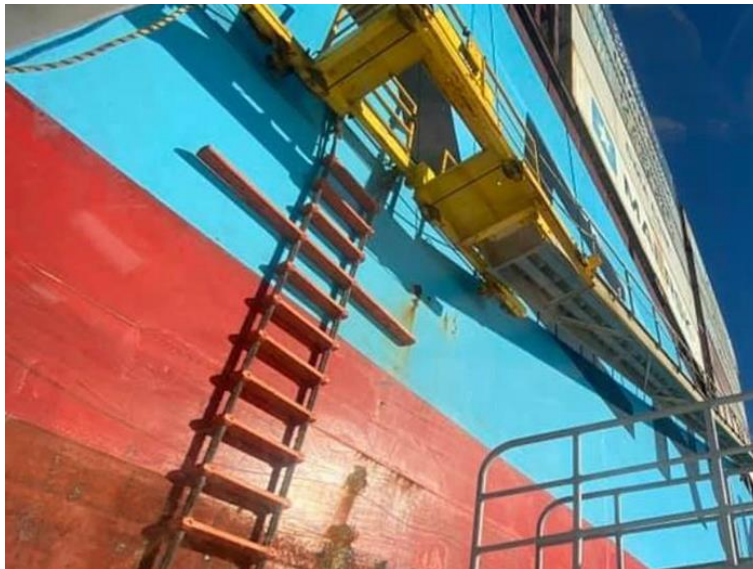

A non-compliant trapdoor arrangement: Pic: Marinelog article

To address the above problems, in 2020 there have been modifications to this system on some ships, which solves the above problems, provided that the system is secured to the ship's hull on the level of the platform. The below picture shows how a compliant trapdoor arrangement should look like.

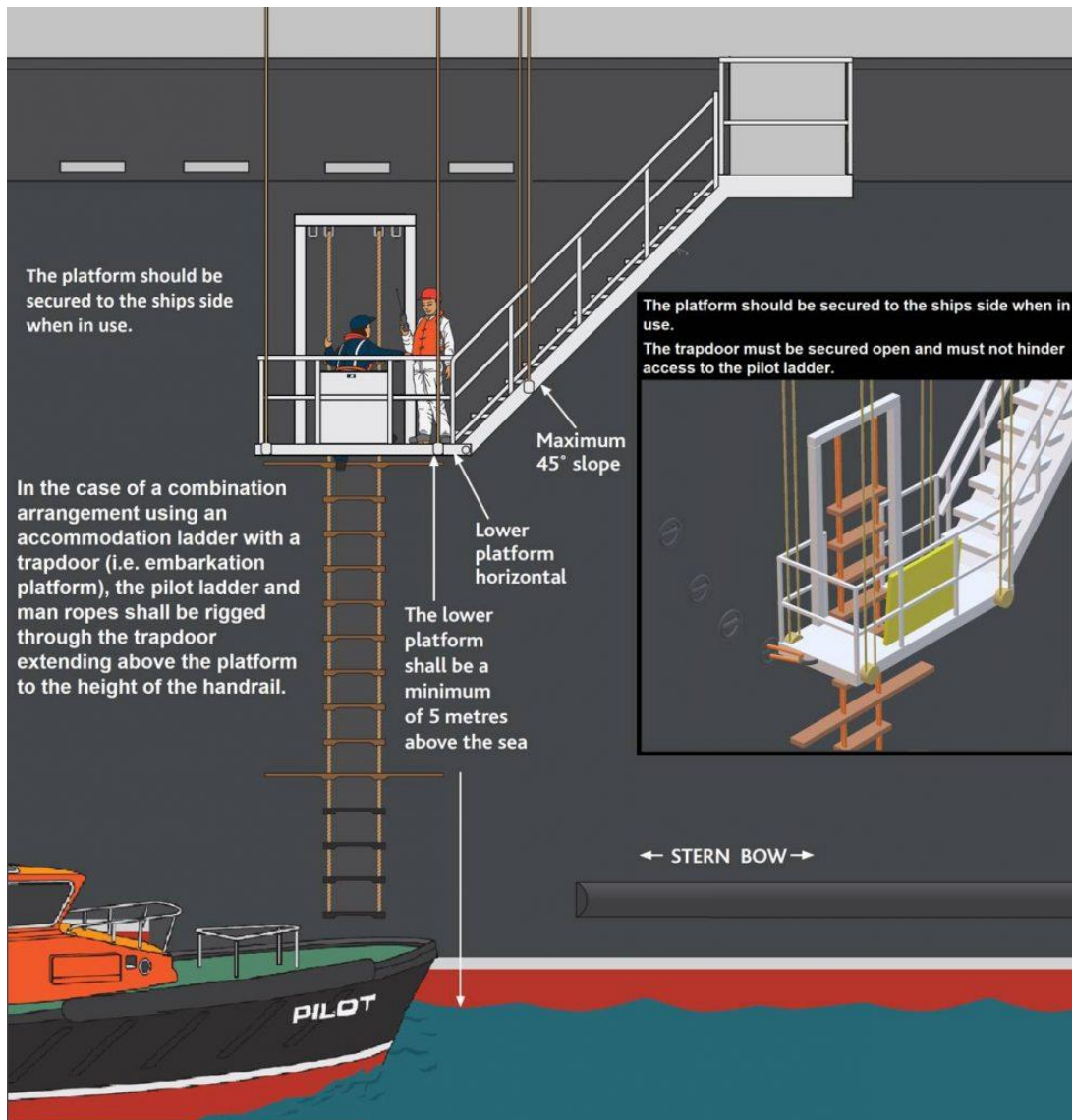

Trapdoor Arrangements: Detail of proposed change to the wheelhouse poster

The Safe Working Load (SWL) of the winch that holds the platform arrangement, must at least be a SWL of sufficient strength to cope with the weight of the platform, accommodation ladder, max number of persons on the arrangement plus 96kN. Also a mechanical locking device must be in place and used.



Trapdoor Arrangement 2.0 (pic: Capt Osorio)

QUIZ 5. Combination Ladders

(Correct answers: see last page of this document)

For the purpose of these questions "freeboard" is " the distance from the surface of the water to the point of access to the ship" (as per Solas V/23 reg 3.3.2)

1. The combination ladder should be used ...

- A. ... when the freeboard is more than 5 meters, so the pilot boat can fit underneath
- B. ... when the freeboard is less than 9 meters
- C. ... when the freeboard is more than 9 meters
- D. ... when the total length of the pilot ladder is more than 9 meters

2. The railings and stanchions of the accommodation ladder must be used ...

- A. ... on the inside of the accommodation ladder and platform only
- B. ... on the outside of the accommodation ladder and platform only
- C. ... on both sides (inside and outside) of the accommodation ladder and platform
- D. ... on request of the pilot only

3. On how many places should the combination ladder arrangement be secured to the ship's side?

- A. None, it is not needed
- B. One (combination ladder)
- C. Two (accommodation ladder plus one side rope of the pilot ladder)
- D. Three (accommodation ladder plus both side ropes of the pilot ladder)
- E. More (accommodation ladder plus all steps of the pilot ladder)

- 4. When the combination ladder is used, the pilot ladder should be secured to deck as follows:**
- A. On the winch
 - B. Using a D-shackle, a steel bar, a deck tongue, or a spreader
 - C. Like any other pilot ladder used on its own
 - D. By means of two strong crew members

SOLAS V – Reg 23

Transfer Arrangements

3.3: Safe and convenient access to, and egress from, the ship shall be provided by either:

.2. an accommodation ladder in conjunction with the pilot ladder (i.e. a combination arrangement), or other equally safe and convenient means, whenever the distance from the surface of the water to the point of access to the ship is more than 9 m. The accommodation ladder shall be sited leading aft. When in use, means shall be provided to secure the lower platform of the accommodation ladder to the ship's side, so as to ensure that the lower end of the accommodation ladder and the lower platform are held firmly against the ship's side within the parallel body length of the ship and, as far as is practicable, within the mid-ship half length and clear of all discharges.

.1. when a combination arrangement is used for pilot access, means shall be provided to secure the pilot ladder and manropes to the ship's side at a point of nominally 1.5 m above the bottom platform of the accommodation ladder. In the case of a combination arrangement using an accommodation ladder with a trapdoor in the bottom platform (i.e. embarkation platform), the pilot ladder and man ropes shall be rigged through the trapdoor extending above the platform to the height of the handrail.

IMO 1045(27) Pilot Transfer Arrangements:

3 Accommodation ladders used in conjunction with pilot ladders

3.1 Arrangements which may be more suitable for special types of ships may be accepted, provided that they are equally safe.

3.2 The length of the accommodation ladder should be sufficient to ensure that its angle of slope does not exceed 45°. In ships with large draft ranges, several pilot ladder hanging positions may be provided, resulting in lesser angles of slope. The accommodation ladder should be at least 600 mm in width.

3.3 The lower platform of the accommodation ladder should be in a horizontal position and secured to the ship's side when in use. The lower platform should be a minimum of 5 m above sea level.

3.4 Intermediate platforms, if fitted, should be self-levelling. Treads and steps of the accommodation ladder should be so designed that an adequate and safe foothold is given at the operative angles.

3.5 The ladder and platform should be equipped on both sides with stanchions and rigid handrails, but if handropes are used they should be tight and properly secured. The vertical space between the handrail or handrope and the stringers of the ladder should be securely fenced.

3.6 The pilot ladder should be rigged immediately adjacent to the lower platform of the accommodation ladder and the upper end should extend at least 2 m above the lower platform. The horizontal distance between the pilot ladder and the lower platform should be between 0.1 and 0.2 m.

3.7 If a trapdoor is fitted in the lower platform to allow access from and to the pilot ladder, the aperture should not be less than 750 mm x 750 mm. The trapdoor should open upwards and be secured either flat on the embarkation platform or against the rails at the aft end or outboard side of the platform and should not form part of the handholds. In this case the after part of the lower platform should also be fenced as specified in paragraph 3.5 above, and the pilot ladder should extend above the lower platform to the height of the handrail and remain in alignment with and against the ship's side.

3.8 Accommodation ladders, together with any suspension arrangements or attachments fitted and intended for use in accordance with this recommendation, should be to the satisfaction of the Administration¹.

¹Refer to SOLAS regulation II-1/3-9 concerning accommodation ladders.

SOLAS II-1/3-9:

Regulation 3-9. Means of embarkation on and disembarkation from ships

1. Ships constructed on or after 1 January 2010 shall be provided with means of embarkation on and disembarkation from ships for use in port and in port related operations, such as gangways and accommodation ladders, in accordance with paragraph 2, unless the Administration deems that compliance with a particular provision is unreasonable or impractical .
2. The means of embarkation and disembarkation required in paragraph 1 shall be constructed and installed based on the guidelines developed by the Organization .
3. For all ships the means of embarkation and disembarkation shall be inspected and maintained in suitable condition for their intended purpose, taking into account any restrictions related to safe loading. All wires used to support the means of embarkation and disembarkation shall be maintained as specified in regulation III/20.4.:

Regulation 20.4 Operational readiness, maintenance and inspections: Maintenance of falls

Falls used in launching shall be inspected periodically with special regard for areas passing through sheaves, and renewed when necessary due to deterioration of the falls or at intervals of not more than 5 years, whichever is the earlier.

Chapter 6: Safe Approach



*The AQUILA alongside a ship.
Note the the massive MOB installation on her stern*

The safe approach of the pilot boat depends on many factors. The main ones are dependent on the vessels characteristics and layout, loading condition and the place for embarkation.

The minimum length of 1,5 meters is very important for safe embarkation and disembarkation. It allows the pilot to step on to the pilot ladder, while at the same time holding on to a side rope. It is very difficult to hang on, while standing on a ladder, when your hands are at waist level, as can be seen in the below picture.



*The minimum length of 1,5 m can barely be achieved
on a small freeboard tanker*

There should be no fendering near the pilotladder arrangement

Dependent of the ship's freeboard and draft, it is possible that there is not a standard solution for placing the ladder. For instance, when the pilot boat requires a height of 2 meters above the waterline, and a minimum pilot ladder length of 1,5 m is required, a minimum freeboard of 3,5 m is required. On some coasters that may not be possible from the main deck.



*Fendering is clear in way of the pilot ladder
(The gap should be 6m though!)*

By design, there should be no fendering near the pilot ladder. On ships where fendering gets in the way of the pilot ladder, pilot tender or fast launch craft, dangerous situations can occur. On one occasion a fast launch was overturned by a fender tipping over the launch. Four people ended up in the water as a result.

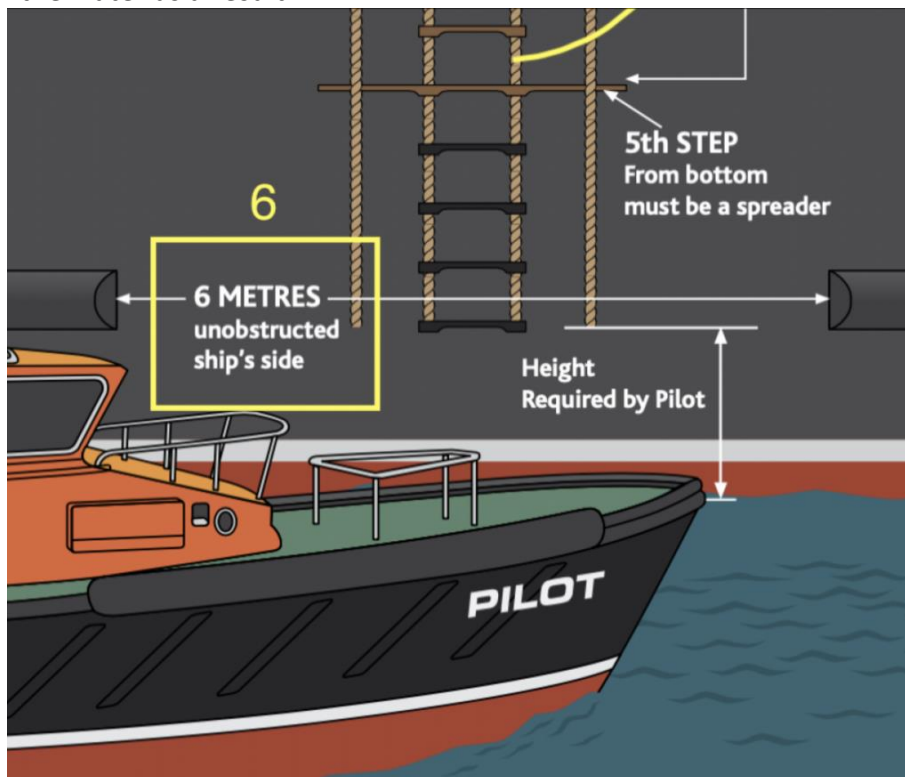

Safe Approach; Detail of Wheelhouse poster

On some ships, in particular ferries and roro-vessels, the gate to the pilot ladder is located so far aft, that the tender or launch can end up under the stern of the ship, close to the ship's

propeller. The best position of the pilot ladder is close to the midships position, and always within the parallel body length of the ship.



Rotterdam pilot speed tender

Main Items to keep in mind:

1. Embarkation point is well lit
2. No fendering around the pilot ladder
3. No overboard discharge near the pilot ladder

QUIZ 6. Safe Approach

(Correct answers: see last page of this document)

1. **The best place for the pilot ladder to be rigged is...**
 - A. In the position of the lowest freeboard
 - B. Close to the accommodation, so the pilot does not have to walk a long distance
 - C. Close to the midships, within the parallel body of the ship
 - D. Where it is most convenient for the deck crew
2. **The following can be said of fendering in way of the pilot access point:**
 - A. There should be no fendering at all for 6 meters or more in total
 - B. Fendering should be rounded to avoid damage to the pilot boat
 - C. Fendering should be made of soft material
 - D. Mobile fendering should be used when the pilot boat comes alongside
3. **Adequate Lighting should be provided ...**
 - A. ... always
 - B. ... never
 - C. ... on request of the pilot

SOLAS V Reg 23:

3.3. Safe and convenient access to, and egress from, the ship shall be provided by either:

.1. a pilot ladder requiring a climb of not less than 1.5 m and not more than 9 m above the surface of the water so positioned and secured that:

- .1. it is clear of any possible discharges from the ship;
- .2. it is within the parallel body length of the ship and, as far as is practicable, within the mid-ship half length of the ship;
- .3. each step rests firmly against the ship's side; where constructional features, such as rubbing bands, would prevent the implementation of this provision, special arrangements shall, to the satisfaction of the Administration, be made to ensure that persons are able to embark and disembark safely;

8. Lighting

Adequate lighting shall be provided to illuminate the transfer arrangements overside and the position on deck where a person embarks or disembarks.

IMO 1045(27) Pilot Transfer Arrangements:

6 Safe approach of the pilot boat

Where rubbing bands or other constructional features might prevent the safe approach of a pilot boat, these should be cut back to provide at least 6 metres of unobstructed ship's side. Specialized offshore ships less than 90 m or other similar ships less than 90 m for which a 6 m gap in the rubbing bands would not be practicable, as determined by the Administration, do not have to comply with this requirement. In this case, other appropriate measures should be taken to ensure that persons are able to embark and disembark safely.

Chapter 7: Access to Deck

Think of your own safety! Every year, seafarers are lost overboard at sea when rigging a pilot ladder. The first precaution to take when rigging a ladder is to ensure it is done by at least two men, who wear lifejackets, safety lines and a radio. Also, during the embarkation or disembarkation of the pilot, wearing a lifejacket is advisable, since the embarkation point is usually located near an opening in the ship's railing.

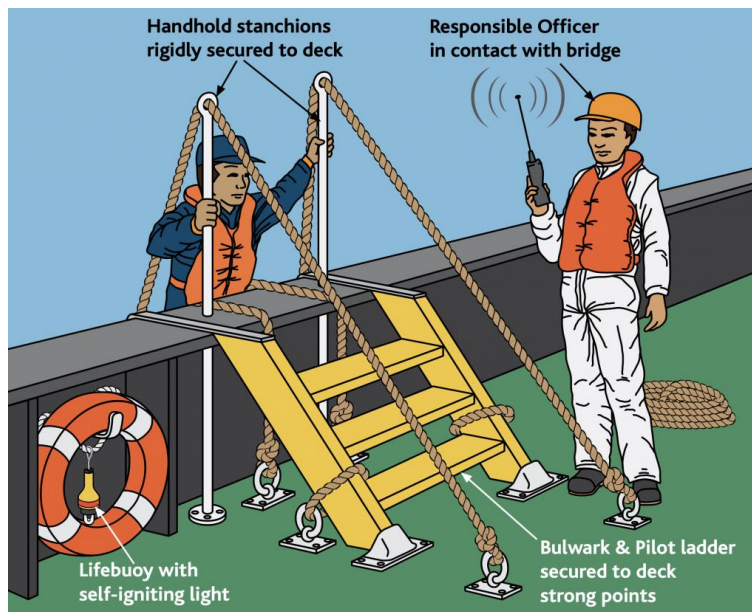

Access to Deck Detail of Wheelhouse poster

With the present minimum manning levels on ships, there is little time to perform crucial tasks such as rigging the pilot ladder properly. It is the usual last job after departure, or the first job before arrival of the ship into port. However, the critical nature of the operation for which a pilot ladder is used does not allow for any shortcuts.

Wearing a lifejacket is advisable, since the embarkation point is usually located near an opening in the ship's railing

The lifebuoy with self-igniting light is mandatory at the location of the pilot embarkation point, and for a good reason. Whenever a pilot goes into the water by accident, this buoy will mark the spot where he fell in. That is where all rescue operations will be aimed at. Ensure it is working and ready for use.

QUIZ 7. Access To Deck

(Correct answers: see last page of this document)

1. **The pilot ladder can be rigged overboard using the following methods: (Multiple answers possible)**
 - A. Over the ship's railing
 - B. Over the side
 - C. Over a bulwark
2. **The following items should be present all the time at the pilot access point: (Multiple answers possible)**
 - A. Manropes (if requested by the pilot)
 - B. Lifebuoy
 - C. Lifebuoy light
 - D. Lifebuoy smoke indicator
 - E. Epirb
 - F. Heaving Line
 - G. Visitor's logbook
3. **The bulwark ladder (when used) must be secured as follows:**
 - A. It should be loose all the time
 - B. Secured to the bulwark
 - C. Secured to deck
4. **The pilot should be directed to the bridge as follows:**
 - A. Supervised by a responsible officer with means of communication to the bridge
 - B. By means of clear signs on deck
 - C. By any crew member on deck

Solas Ch V Reg 23:

2. General

2.2: "The rigging of the pilot transfer arrangements and the embarkation of a pilot shall be supervised by a responsible officer having means of communication with the navigation bridge and who shall also arrange for the escort of the pilot by a safe route to and from the navigation bridge."

7. Associated Equipment

7.1. The following associated equipment shall be kept at hand ready for immediate use when persons are being transferred:

1: two man-ropes of not less than 28 mm and not more than 32 mm in diameter properly secured to the ship if required by the pilot; man-ropes shall be fixed at the rope end to the ring plate fixed on deck and shall be ready for use when the pilot disembarks, or upon request from a pilot approaching to board (the manropes shall reach the height of the stanchions or bulwarks at the point of access to the deck before terminating at the ring plate on deck);

2: a lifebuoy equipped with a self-igniting light;

3: a heaving line."

7.2. When required by paragraph 4 above, stanchions and bulwark ladders shall be provided.

8. Lightning

Adequate lighting shall be provided to illuminate the transfer arrangements overside and the position on deck where a person embarks or disembarks.”

Chapter 8: Handholds and Stanchions

Solas V Reg 23 section 4 regulates “Access to deck”. In this section the use of handholds and stanchions is made mandatory. The technical aspects of these regulations can be found in the guidelines IMO 1045 section 5.

The difference between handholds and stanchions, and which of the two should be used, can easily be determined as follows:

1: **Handholds** should be provided when a **gateway** is used. The description of the dimensions of these handholds is very specific and therefore easy to follow:

1. They should be between 0.7 and 0.8 meters apart
2. They should be rigidly secured at the base and at a higher point
3. They should have a diameter (so they should be round!) of not less than 32mm
4. They should be a minimum of 1.2 meters high

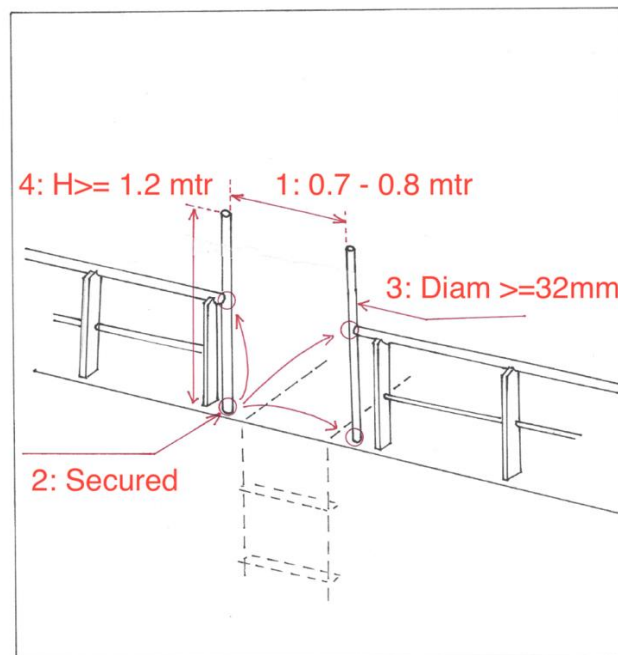

Main features of the handholds

2: **Handhold Stanchions** should be used whenever a **bulwark** is used for access. The requirements (1 – 4 as mentioned above) for these stanchions are the same as the ones used for handholds:

1. They should be between 0.7 and 0.8 meters apart
2. They should be rigidly secured at the base and at a higher point
3. They should have a diameter (so they should be round!) of not less than 32mm
4. They should be a minimum of 1.2 meters high above the bulwark.

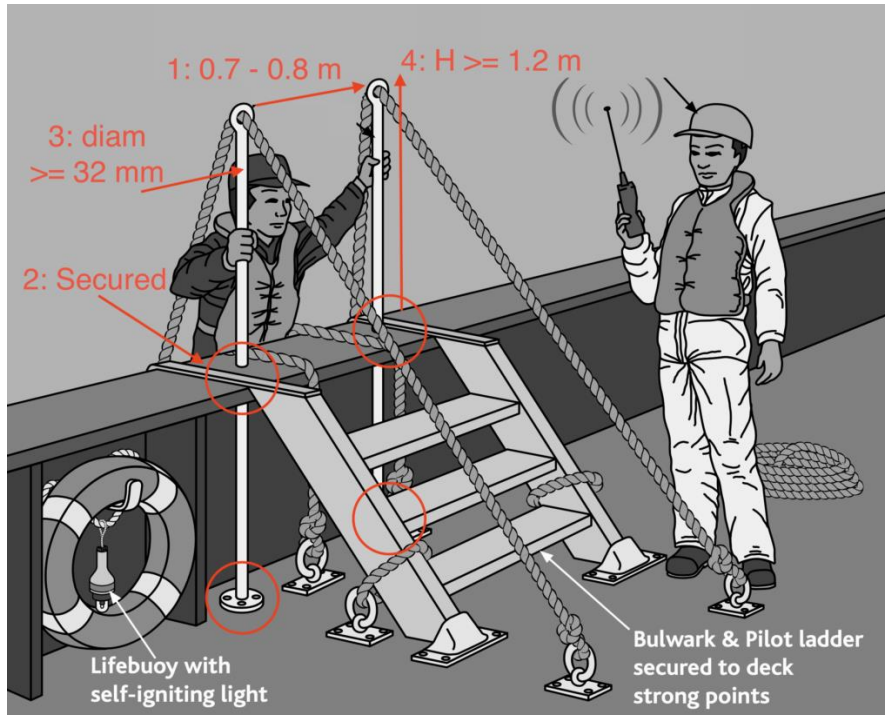

Main features of the handhold stanchions (Detail of Wheelhouse poster)

The absence of handholds can lead to serious accidents as was the case when a Kiel canal helmsman dropped back onto the pilot boat in January 2019. Unfortunately, in many cases, when it comes to the proper use of handholds or stanchions, ships are non-compliant by design.

QUIZ 8: Handholds and Stanchions

(Correct answers: see last page of this document)

1. The difference between handholds and stanchions is: (Multiple answers possible)
 - A. Handholds are used whenever a bulwark is used
 - B. Handholds are used whenever a gate access is used
 - C. Stanchions are used whenever a bulwark is used
 - D. Stanchions are used whenever a gate access is used
 - E. There is no difference between handholds and stanchions
2. In how many places must handholds be secured?
 - A. One (on deck)
 - B. Two (at the base and at a higher point)
 - C. Three or more if possible
3. The length of both handholds and stanchions must be at least ...
 - A. 32 mm
 - B. 1000 mm
 - C. 1200 mm
 - D. 1800 mm
4. The diameter of the handholds and stanchions must be at least ...
 - A. 10 mm
 - B. 32 mm

- C. 64 mm
- D. 128 mm

Solas Ch V Reg 23:

4. Access to the ship's deck

Means shall be provided to ensure safe, convenient and unobstructed passage for any person embarking on, or disembarking from, the ship between the head of the pilot ladder, or of any accommodation ladder or other appliance, and the ship's deck. Where such passage is by means of:

- .1. a gateway in the rails or bulwark, adequate handholds shall be provided;
- .2. a bulwark ladder, two handhold stanchions rigidly secured to the ship's structure at or near their bases and at higher points shall be fitted. The bulwark ladder shall be securely attached to the ship to prevent overturning.

IMO 1045(27) Pilot Transfer Arrangements:

5 Access to deck

Means should be provided to ensure safe, convenient and unobstructed passage for any person embarking on, or disembarking from, the ship between the head of the pilot ladder, or of any accommodation ladder, and the ship's deck; such access should be gained directly by a platform securely guarded by handrails. Where such passage is by means of:

1. *a gateway in the rails or bulwark, adequate handholds should be provided at the point of embarking on or disembarking from the ship on each side which should be not less than 0.7 m or more than 0.8 m apart. Each handhold should be rigidly secured to the ship's structure at or near its base and also at a higher point, should be not less than 32 mm in diameter and should extend not less than 1.2 m above the deck to which it is fitted; and*
2. *a bulwark ladder, two separate handhold stanchions should be fitted at the point of embarking on or disembarking from the ship on each side which should be not less than 0.7 m or more than 0.8 m apart. The bulwark ladder should be securely attached to the ship to prevent overturning. Each stanchion should be rigidly secured to the ship's structure at or near its base and also at a higher point, should be not less than 32 mm in diameter and should extend not less than 1.2 m above the top of the bulwarks. Stanchions or handrails should not be attached to the bulwark ladder.*

Chapter 9: Pilot Ladder Reels

The pilot ladder winch reel is an easy way to store and move the ladder. It is important to understand that after unwinding the winch reel, the pilot ladder should be treated as any other pilot ladder when it comes to securing. Additional mechanical locking devices should be in place on the winch reel. The winch can never be the only securing point for the ladder.

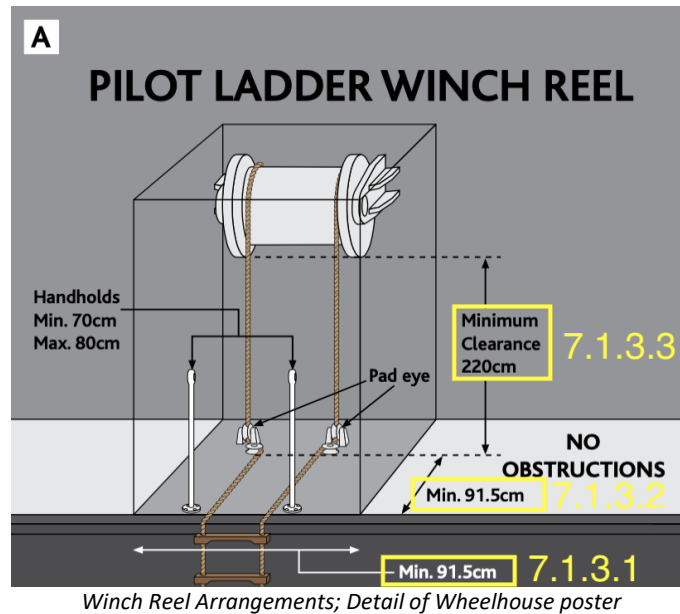

The securing of the pilot ladder is no different when using a pilot ladder winch reel: 7.2.3.3 and 7.4 clearly indicate that when a Pilot Ladder Winch reel is used, the ladder still needs to be secured to strong points on deck. That should be done so that the weight of the ladder is transferred from the side ropes to the designated strong points on deck. See page “[Securing the pilot ladder](#)”. In addition to that, 7.5.6. also stipulates that a mechanical locking device is used to secure the reel itself.

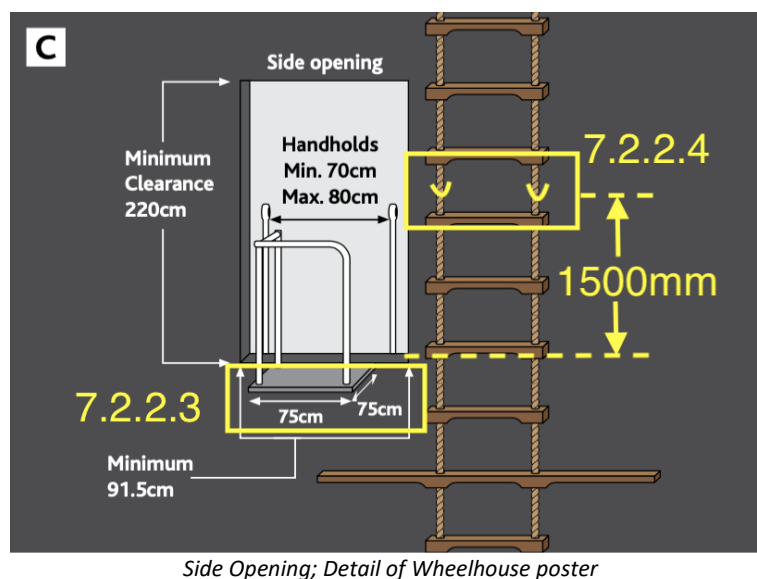

Even when a winch reel is used, the ladder needs to be secured on strong points on deck.

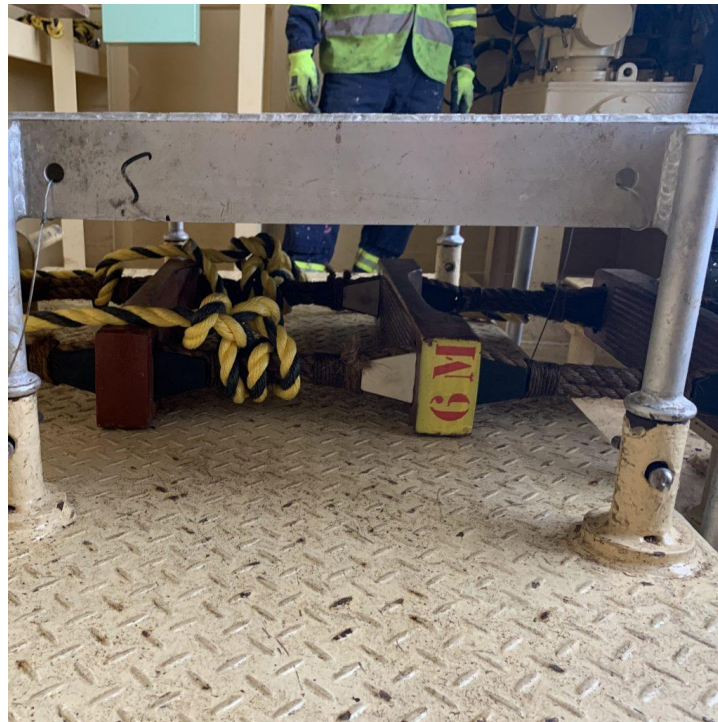

Pilot ladder from a winch, secured by rolling hitch knots.

QUIZ 9: Pilot Ladder Reels

(Correct answers: see last page of this document)

1. **When a pilot ladder reel is used, it should be locked as follows:**
 - A. By leaving the electric, hydraulic, or pneumatic power on all the time
 - B. By using a mechanical locking device
 - C. It should not be locked in position
2. **When a winch on deck is used to lower the ladder to a side opening, the pilot ladder should be secured to the ship side as follows:**
 - A. Securing is not required
 - B. On one side rope, 1500 mm above the pilot access platform
 - C. On two side ropes, 1500 mm above the pilot access platform
3. **When a winch inside the side opening is used, the pilot ladder should be secured as follows:**
 - A. On the winch
 - B. Using D-shackles, Steel bar, Deck tongue or Spreader
 - C. Using strong points on deck by means of a rolling hitch knot or similar

7.1 Point of access

7.1.1 When a pilot ladder winch reel is provided it should be situated at a position which will ensure persons embarking on, or disembarking from, the ship between the pilot ladder and the point of access to the ship, have safe, convenient and unobstructed access to or egress from the ship.

7.1.2 The point of access to or egress from the ship may be by a ship's side opening, an accommodation ladder when a combination arrangement is provided, or a single section of pilot ladder.

7.1.3 The access position and adjacent area should be clear of obstructions, including the pilot ladder winch reel, for distances as follows:

1. a distance of 915 mm in width measured longitudinally;
2. a distance of 915 mm in depth, measured from the ship's side plating inwards; and
3. a distance of 2,200 mm in height, measured vertically from the access deck.

7.2 Physical positioning of pilot ladder winch reels

7.2.1 Pilot ladder winch reels are generally fitted on the ship's upper (main) deck or at a ship's side opening which may include side doors, gangway locations or bunkering points. Winch reels fitted on the upper deck may result in very long pilot ladders.

7.2.2 Pilot ladder winch reels which are fitted on a ship's upper deck for the purpose of providing a pilot ladder which services a ship side opening below the upper deck or, alternatively, an accommodation ladder when a combination arrangement is provided should:

1. be situated at a location on the upper deck from which the pilot ladder is able to be suspended vertically, in a straight line, to a point adjacent to the ship side opening access point or the lower platform of the accommodation ladder;
2. be situated at a location which provides a safe, convenient and unobstructed passage for any person embarking on, or disembarking from, the ship between the pilot ladder and the place of access on the ship;
3. be situated so that safe and convenient access is provided between the pilot ladder and the ship's side opening by means of a platform which should extend outboard from the ship's side for a minimum distance of 750 mm, with a longitudinal length of a minimum of 750 mm. The platform should be securely guarded by handrails;
4. safely secure the pilot ladder and manropes to the ship's side at a point on the ship's side at a distance of 1,500 mm above the platform access point to the ship side opening or the lower platform of the accommodation ladder; and

5. *if a combination arrangement is provided, have the accommodation ladder secured to the ship's side at or close to the lower platform so as to ensure that the accommodation ladder rests firmly against the ship's side.*

7.2.3 Pilot ladder winch reels fitted inside a ship's side opening should:

1. *be situated at a position which provides a safe, convenient and unobstructed passage for any person embarking on, or disembarking from, the ship between the pilot ladder and the place of access on the ship;*
2. *be situated at a position which provides an unobstructed clear area with a minimum length of 915 mm and minimum width of 915 mm and minimum vertical height of 2,200 mm; and*
3. *if situated at a position which necessitates a section of the pilot ladder to be partially secured in a horizontal position on the deck so as to provide a clear access as described above, then allowance should be made so that this section of the pilot ladder may be covered with a rigid platform for a minimum distance of 915 mm measured horizontally from the ship's side inwards.*

7.3 Handrails and handgrips

*Handrails and handgrips should be provided **in accordance with section 5** to assist the pilot to safely transfer between the pilot ladder and the ship, except as noted in paragraph 7.2.2.3 for arrangements with platforms extending outboard. The horizontal distance between the handrails and/or the handgrips should be not less than 0.7 m or more than 0.8 m apart.*

7.4 Securing of the pilot ladder

Where the pilot ladder is stowed on a pilot ladder winch reel which is located either within the ship's side opening or on the upper deck:

1. *the pilot ladder winch reel should not be relied upon to support the pilot ladder when the pilot ladder is in use;*
2. *the pilot ladder should be secured to a strong point, independent of the pilot ladder winch reel; and*
3. *the pilot ladder should be secured at deck level inside the ship side opening or, when located on the ship's upper deck, at a distance of not less than 915 mm measured horizontally from the ship's side inwards.*

7.5 Mechanical securing of pilot ladder winch reel

7.5.1 *All pilot ladder winch reels should have means of preventing the winch reel from being accidentally operated as a result of mechanical failure or human error.*

7.5.2 *Pilot ladder winch reels may be manually operated or, alternatively, powered by either electrical, hydraulic or pneumatic means.*

7.5.3 *Manually operated pilot ladder winch reels should be provided with a brake or other suitable arrangements to control the lowering of the pilot ladder and to lock the winch reel in position once the pilot ladder is lowered into position.*

7.5.4 *Electrical, hydraulic or pneumatically driven pilot ladder winch reels should be fitted with safety devices which are capable of cutting off the power supply to the winch reel and thus locking the winch reel in position.*

7.5.5 *Powered winch reels should have clearly marked control levers or handles which may be locked in a neutral position.*

7.5.6 *A mechanical device or locking pin should also be utilized to lock powered winch reels.*

Chapter 10: Inspection, Maintenance



It is clear from the various regulations there is no set inspection interval for pilot ladders. With regards to maintenance and inspection, SOLAS, ISM, ISO and ISM regulations and guidelines apply:

- **As per Solas Ch.1 regulation 8**, pilot ladders are part of the safety equipment onboard of cargo ships over 500 GT, they are therefore mentioned in the **Cargo Ship Safety Equipment Certificate**.
- As a result of this, pilot ladders must have a valid certificate, which must be onboard at all times.
- Pilot ladders must be **inspected before every use**, as well as on a regular basis as per the ships maintenance system, under the governing ISM code certification. (see below)
- Records of maintenance, repair and inspections of pilot ladders are subject to annual **flag state inspection SOLAS inspections**.
- Pilotladders over 30 months old must have a certificate of strength testing as per **ISO 799-1:2019(E)** " 10.4 Each ladder shall be subjected to the ladder and step attachment strength test in Table 2 at not more than 30-month intervals. Each ladder which fails the test shall be rebuilt according to 10.3, or scrapped. The ladder shall be marked with the date of the test and the identification of the person or company performing the test. This marking shall be placed on the same steps as marking required by 8.1 of this document."

- Pilot ladders that fail an inspection, or that are over 30 months old and have no strength testing certificate, should never be used.

QUIZ 10: Pilot Ladder Reels

(Correct answers: see last page of this document)

1. **Pilot Ladders are part of the ship's safety equipment**
 - A. True
 - B. Not true
2. **Pilot Ladders Should be inspected on the following occasions: (Multiple answers possible)**
 - A. Every day at sea
 - B. On every planned maintenance inspection interval
 - C. Every time it is used
 - D. Every monday morning at 08:00
3. **As per ISM code the following procedures apply to pilot ladders: (Multiple answers possible)**
 - A. Pilot ladders should be inspected at regular intervals as per the ships Safety Management System
 - B. Inspection records should be kept in the company office only
 - C. Inspection records should be kept onboard only
 - D. Inspection records should be kept at all relevant locations (onboard and ashore)

SOLAS V Reg 23: 2. General

2.1. All arrangements used for pilot transfer shall efficiently fulfil their purpose of enabling pilots to embark and disembark safely. The appliances shall be kept clean, **properly maintained** and stowed and shall be **regularly inspected** to ensure that they are safe to use. They shall be used solely for the embarkation and disembarkation of personnel.

As per ISM code, the International Safety Management Code (Resolution A.741(18)) :

10 Maintenance of the ship and equipment

10.1 The Company should establish procedures to ensure that the ship is maintained in conformity with the provisions of the relevant rules and regulations and with any additional requirements which may be established by the Company.

10.2 In meeting these requirements the Company should ensure that:

1. inspections are held at appropriate intervals;
2. any non-conformity is reported with its possible cause, if known;
3. appropriate corrective action is taken; and
4. records of these activities are maintained.

10.3 The Company should establish procedures in SMS to identify equipment and technical systems the sudden operational failure of which may result in hazardous situations. The SMS

should provide for specific measures aimed at promoting the reliability of such equipment or systems. These measures should include the regular testing of stand-by arrangements and equipment or technical systems that are not in continuous use.

10.4 The inspections mentioned in 10.2 as well as the measures referred to 10.3 should be integrated in the ship's operational maintenance routine. [Permanente link](#)

11 Documentation*

11.1 The Company should establish and maintain procedures to control all documents and data which are relevant to the SMS.

11.2 The Company should ensure that:

1. valid documents are available at all relevant locations;
2. changes to documents are reviewed and approved by authorized personnel; and
3. obsolete documents are promptly removed.

11.3 The documents used to describe and implement the SMS may be referred to as the "Safety Management Manual". Documentation should be kept in a form that the Company considers most effective. Each ship should carry on board all documentation relevant to that ship.

* Refer to the *Revised list of certificates and documents required to be carried on board ships* (FAL.2/Circ.127, MEPC.1/Circ.817 and [MSC.1/Circ.1462](#)).

Chapter 11: Marking, Certification

Every pilot ladder should have certain markings and certificates to go along with it. Let's have a look at a random pilot ladder on board and the paperwork that belongs to it:

SOLAS 2.4. All pilot ladders used for pilot transfer shall be clearly identified with tags or other permanent marking so as to enable identification of each appliance for the purposes of survey, inspection and record keeping. A record shall be kept on the ship as to the date the identified ladder is placed into service and any repairs effected.

For this example, we use the guidelines ISO 799-1:2019 to explain the various Markings and notations. Every pilot ladder should have a serial number marked as per ISO-799 section 8 as follows: The bottom of the top step and bottom of the lowest spreader step of the ladder shall be marked with:

- The name and the address of the manufacturer
- The Manufacturer's model designation
- "ISO 799-1" and "SOLAS"
- the year of assembly or reassembly of the ladder
- identification of the approved maritime safety administration, along with any approval indications required by that administration
- where used, identification of an approved organization acting on behalf of the maritime safety administration.
- If a replacement step is used, the words "REPLACEMENT STEP ONLY" shall be used as well.



Marking under the step of the mentioned ladder

This is for instance a PTR Goliath ladder marked with all of the above items, except for the fact that ISO 799:2004 is still mentioned. This standard has now been replaced by ISO-799-1:2019



Name tag plate of the mentioned pilot ladder

The name tag plate on this ladder displays a few important items that can be cross referenced with the certificate: Type, Model, Length, Production date, as well as the serial number (Prod.No) and the approval standard.

There are **3 logo's** on the top of this plate, which are important in this respect:

- **The DNV-GL logo**, the classification society that type approves this ladder, as well as the Manufacturing Company.
- **The PTR Holland logo**, which is the logo of the Manufacturing Company
- **The Steering wheel**, marked with MED, as well as the number 0575. The symbol and “MED” stands for Marine Equipment Directive 4.49, the EU standard for pilot ladders for all EU flagged vessels. The number indicates the EU designated number of the “Notified Body” which is DNV GL in this case.



PTR HOLLAND® GROUP
 ROTTERDAM · SINGAPORE · HOUSTON · NEWCASTLE · QINGDAO PRD

EUROPEAN COMMUNITY DECLARATION OF CONFORMITY	
We hereby declare that the following specified equipment complies with the Marine Equipment Directive 2014/90/EU	
Equipment description	: Pilot ladder (MED / 4.49)
Type	: Goliath
Ladder/Serial No.	: 3156773
Ladder Length (mtr)	: 3.30mtr
Date of manufacture	: 07/03/2018
Manufacturer	: PTR Holland Group
Manufacturer address	: Dintelweg 107, 3198 LB, Europoort Rotterdam, The Netherlands.
Equipment intended for:	
Purchaser	:
Vessel Name	:
Purchase Order No.	:
This equipment has been tested to verify compliance with the following Regulations and Testing Standards:	
- Type approval requirements	: SOLAS 74 Reg. V/23 & SOLAS 74 Reg. X/3
- Carriage and performance requirements	: SOLAS 74 Reg. V/23, X/3 IMO Res. A.1045(27) IMO Res. MSC/Circ. 1428
- Testing Standards	: IMO Res. A.1045(27) & ISO 799:2004.
EC Type-Examination Certificate No. (for module B)	: MEDB00002T9
Issued By	: DNV GL / 0575
Quality System Certificate No. For module D	: MEDD0000154
Issued By	: DNV GL / 0575
Technical documentation for this equipment is retained at the following address:	: info@ptrholland.com
Marking and stamping / Marquage:	 0575 / 2018
SIGNED ON BEHALF OF THE MANUFACTURER	DNV-GL
Name	:
Position	:
Place & date	: Rotterdam, 07/03/2018
Register your rope ladder and receive a free 30 months mandatory load test www.ptrholland.com/load-test-registration/ 	

Certificate of the above mentioned ladder

The certificate that goes along with this ladder shows the following items:

- Statement that the ladder complies with MED 2014/90/EU
- Description: Type of equipment, and the MED category (4.49)
- Type: Manufacturers Type “Goliath”
- Serial No. “3156773” (Corresponding with the serial number on the ladder)
- Ladder Length(m) (Corresponding with the length on the ladder)
- Date of manufacture: 07/03/2018. (Corresponding with the date on the ladder) **
- Manufacturer: (Corresponding with the manufacturer on the ladder)
- Manufacturer Address
- Vessel name

- The standards, resolutions and regulations to which the ladder complies: In this case ISO-799, Solas and IMO res 1045(27)
- The EC-Type-Examination certificate issued for this type of ladder: in this case its number is MEDB00002T9 (Corresponding with the number on the ladder) , issued by DNV GL (number 0575). This certificate goes by the name of : “EC-Type Examination Certificate (Module B)”. (The manufacturer of this ladder also issues a copy of this document with the ladder)
- The Quality System Certificate No. is the certificate issued by classification society DNV GL about the Quality System of the Manufacturer. This certificate goes by the name of : “QS-Certificate of Assessment – EC (Module D)”. (The manufacturer of this ladder also issues a copy of this document with the ladder)
- The Steering Wheel symbol of MED 4.49: same as on the ladder (see above)
- The Logo of the classification society.
- The signature on behalf of the manufacturer
- Registration QR code: The manufacturer of these ladders uses blockchain technology to keep track of the ladders produced. On the latest ladders, the steel plate on the ladder also shows the same QR code. This allows inspectors to easily scan the pilot ladder and check online if all specifications are correct. (see below)

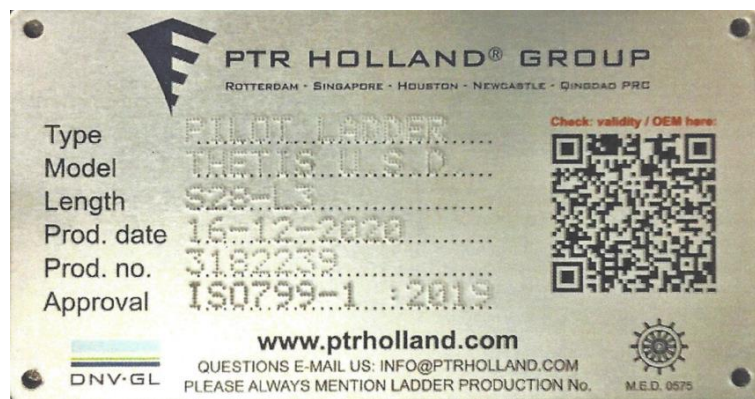

Pilot Ladder name tag with QR code

** In this case the ladder is over 30 months old, and therefore a certificate of load testing should be present as well.

Apart from this certificate, there should be a record of repairs, and a record of maintenance of the pilot ladders onboard.

Case study: Something is not right here: A fake certificate?

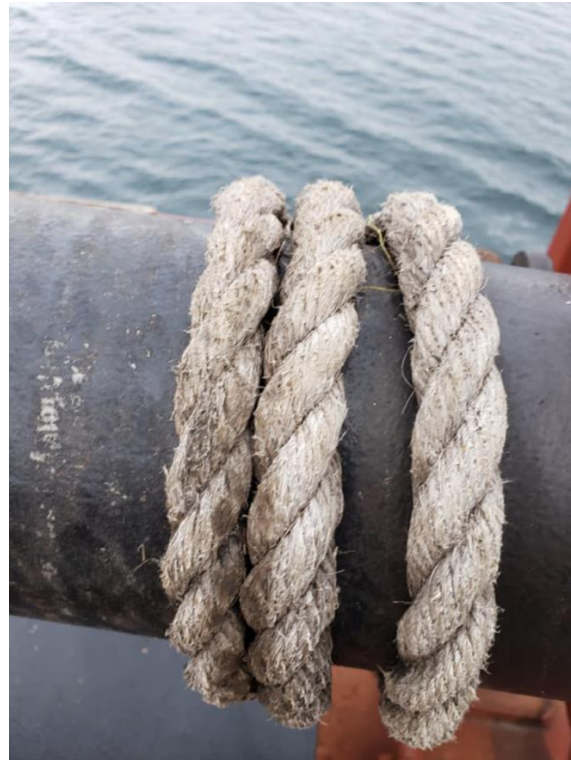
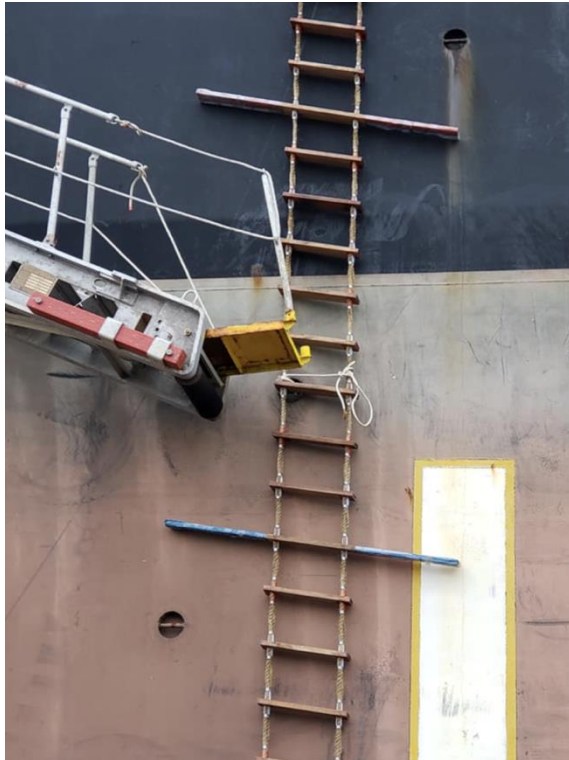

The above ladder was presented in December 2020, when the pilot boarded a vessel: Securing incorrect, Steps not straight, Inner stanchion is missing, coating or tape on the spreaders...

The rope work of the pilot ladder looks very old and worn out.

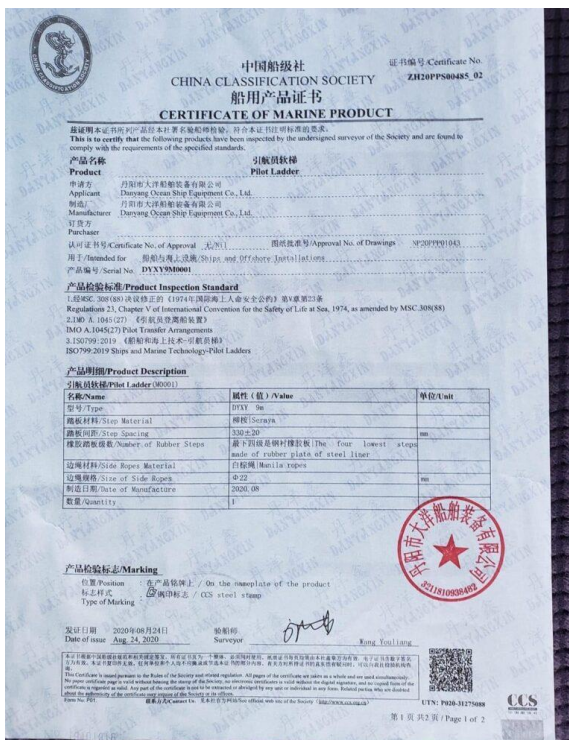

The ladder in question is badly rigged and appears to be in a very bad state. Much to the surprise of the pilot, he was presented with the following documentation of this pilot ladder by the master of the ship:

These documents indicate that the pilot ladder in question was **only 4 months old** at the time. There are references made to SOLAS, IMO 1045 and ISO 799-1:2019. Also there are “official” stamps by the China Classification Society (CCS) on these documents.

中国船级社 证书格式号/Form: P01.03-HQ001079
CHINA CLASSIFICATION SOCIETY
船用产品证书
CERTIFICATE OF MARINE PRODUCT
 证书编号/Certificate No. PE18P00001.02

兹证明相应 VEEM Ltd 的申报, 下列产品经本社注册验船师检验, 符合本证书注明标准的要求。
This is to certify that, upon request of VEEM Ltd
 the following products have been inspected by the undersigned the surveyor of the Society and are found to comply with the requirements of the specified standards.

制造厂名 VEEM Ltd
 Manufacturer VEEM Ltd
 订货方 澳克斯船舶科技有限公司
 Purchaser Aoxing Shipbuilding Co., Ltd.
 产品名称 铜合金螺旋桨
 Product COPPER ALLOY PROPELLER
 认可证书号/Cert.No. of Approval: 无/N/A 图纸批准号/Approval No. of drawings: GP18C014.0005H

附加标志 无/N/A
 Notations 无/N/A
 用于 国内航行海船/Domestic sea-going ship
 Intended for 国内航行海船/Domestic sea-going ship
 船舶工程号 AL002
 Hull No. AL002
 产品使用限制 无/N/A
 Restriction for application of product 无/N/A
 产品编号 165818/1
 Serial No. 165818/1
产品检验标准/ Product Inspection Standard

1. Chapter 9, Part One of China Classification Society Rules for Material and Welding 2018 and Its Amendments.
 中国船级社《材料与焊接规范》(2018)及其修改通报第一版第9章

产品检验标志/Marking
 位置/Position 在产品上/ On the product
 标志样式/Type of Marking CS PE18P00001.02 CCS钢印标志/ CCS steel stamp
 发证日期 2018年11月20日
 Date of Issue 165818/1 验船师 Yang Chengkun
 Surveyor Yang Chengkun

本证书遵循中国船级社《船用产品检验规范》的有关规定制定, 用于证明符合船级社证书注明的技术规范。本证书由船级社签发, 船级社证书为一类标志, 必须保持完整。每一张证书均以船级社盖章为有效, 证书复印件无效。任何单位和个人不得擅自复制或在本证书复印件上作任何更改, 否则本社保留追究其法律责任的权利。
 This Certificate is issued pursuant to the Rules for Classification of Sea-going Steel Ships and related provisions of the Society. Refer to the back of the certificate for detailed requirements of the certificate. When the certificate consists of more than one page, all pages of the certificate are taken as a whole and are used simultaneously. No certificate page is valid without bearing the stamp of the Society and no copy from the certificate is regarded as valid. Any part of the certificate is not to be corrected or changed by any unit or individual in any form. Related parties who are directed about the authenticity of the certificate may require of the Society or its offices.

中国船级社总部: CCS Headquarter: 北京东便门大街1号/Beijing East Gate 1st Street 邮编: 100007 电话/Tel: +86(10)85112108 传真/Fax: +86(10)85112103
 CCS Headquarter: Beijing East Gate 1st Street 100007, China 邮编/Post Code: 100007 电话/Phone: +86(10) 85112108 传真/Fax: +86(10) 85112103
 中国船级社(上海)分公司: CCS Branch Office: 中国上海浦东大道100号 CCS Shanghai Office: 电话/Tel: +86(21) 50606022 传真/Fax: +86(21) 50606027
 CCS Branch Office: 1000 Pudong Avenue, Shanghai, China 电话/Phone: +86(21) 50606022 传真/Fax: +86(21) 50606027

PE50147683
 No. 10308794

第 1 页 共 3 页 / Page 1 of 3

In a similar case in 2019, the Australian Marine Pilots Institute (AMPI) asked CCS for a copy of a real (Pilot Ladder) Certificate and they were presented with this document:
 Source AMPI.org.au

The format of this certificate shows that the presented "Certificate of marine Product" onboard was probably a fake certificate, issued with a very old, used or second-hand pilot ladder.

Chapter 12: Pilot Ladder Checklist

Use this checklist every time the pilot ladder is rigged

1. The Pilot Ladder

- Is the pilot ladder in good shape?
 - Check for wear and tear, missing chocks, loose steps.
 - Check for broken steps or spreaders.
- Are all steps and ropes clean and free of grease?
- Is all extra equipment present and ready for use?
 - Lifebuoy and light
 - Manropes if required by pilot
 - Heaving line
 - Lifejacket
 - Responsible officer with communication to bridge.
- Is the pilot ladder rigged to the correct height?
- Has the retrieval wire been rigged correctly? (above the spreader, leading forward)
- Has the pilot ladder been secured to the deck in a correct way?
- Haven stanchions and/or bulwark ladder been fitted and secured to the deck?
- Is there adequate lighting at the pilot access point?

2. The Combination Ladder

- Is the accommodation ladder in good shape?
- Check the accommodation ladder for wear and tear.
- Check if steps and siderails are free of grease.
- Is the retrieval line of the pilot ladder rigged correctly? (Above the spreader leading forward)
- Is the accommodation ladder secured to the ships side, independent of the ladder?
- Is there at least 5 meters of space under the platform?
- Is the platform rigged horizontally?
- Are all hand railings and hand ropes rigged correctly, both inboard and outboard?
- Does the pilot ladder extend 2 meters above the platform?
- Have both pilot ladder ropes been secured to the ship, at 1.5 meters above the platform?

3. Winch Reel

- Ensure the winch reel is mechanically locked
- Ensure the pilot ladder is secured to deck

Reference

IMO resolution A.1045 (27)

Solas Chapter V, regulation 23 (Safety of navigation)

IMO/IMPA Bridge Poster " Required Boarding Arrangement for Pilot"

ISO Standard 799 – Pilot Ladders

Book: "Pilot Ladder Manual- Advanced edition" by Kevin Vallance

CHIRP Maritime – Pilot Ladders – Error Enforcing Conditions and Deficiencies

Sullom Voe Harbour Authority Pilot Ladder Booklet

"1000 Ways to Secure a Pilot Ladder" , "1000 Ladders Around " , "1000 Combinations Around " by Arie Palmers (2020)

Record of changes

Date	Item
2020 July	Page 6: Typo error in the strength of the ropes (24 kN)
	Page 4: Regulations regarding Pilot Ladder Safety.
	Foreword added
2020 August	P11: "Rigging of Pilot Ladder Poster" added
	P14: Retrieval Line Diagram added
	P23: SWL of a trapdoor arrangement winch
	P26: Picture AQUILA added
	P26: Picture and text of a short ladder added
2020 December	Various chapters rewritten
	Chapter "Maintenance and Inspection" Added
	Chapter "Who's onboard" added
2021 March	Chapter "Handholds and Stanchions" has been added Chapter "Marking, Certification " has been added Chapter Reference has been added
2021 April	Checklist (P.46) has been updated Inner stanchion use added to "Combination Ladders"
2021 July	Added a Quiz to each section of the website Added bad practice examples to "Securing the pilot ladder"

Who's Onboard

If you wish to join the growing network of maritime pilots and experts involved in Pilot Ladder Safety by adding a contribution or endorsing this initiative, send an e-mail to info@pilotladdersafety.com

The website is open to any contributors who wish to give feedback or publish articles aimed at improving Pilot Ladder safety.



The following persons or organizations have endorsed, supported or contributed to the content of this website.

- Capt. Arie Palmers, Maritime Pilot Scheldemonden Region, Netherlands, co- author of the “Dangerousladders” facebook group
- Capt. Gary Clay, Maritime Pilot, Founder of Fathom Safety, United Kingdom
- Capt. Jesus Señeriz Lopez , Maritime pilot , Spain , Author of Guía para el transbordo de prácticos LINK
- Capt. Sarnbir Sing Sawhney , Marine Superintendent
- Capt. Wim van Buuren, Maritime Pilot, Port of Rotterdam, The Netherlands
- Capt. Troy Evans, Maritime Pilot, Tugmaster , Port of Tauranga, New Zealand
- Massachusetts Maritime Academy, Capt. Ashok Pandey, Associate Professor International Maritime Business LINK
- The American P&I Club (American Steamship Owners Mutual Protection and Indemnity Association, Inc) Dr. Willam Moore, Daniele Centeno
- Norwegian Pilots Association Capt. Johannes Sivertsen , President
- Danpilots, Denmark’s State Pilots Capt. Niels Bergmann Rasmussen
- Rio de Janeiro Pilots Association Capt. Porthos Lima, Operations Director
- All India Maritime Pilot Association Capt. Gajanan Karanjikar
- American Pilots’ Association Capt. Jorge Viso, President
- PTR Holland Joris J. Stuip , Global General Manager / VP.
- Fremantle pilots, Australia, Capt. Trevor Bozoky
- Baranquilla Pilots Carlos Andres Cantor, Manager
- Lloyd’s Register Mr. Erik Mooij, Group Senior HSES Manager

Quiz Answers

- QUIZ 1: Regulatory framework: 1A 2B 3D 4C
- QUIZ 2: Securing The Pilot Ladder: 1B 2B 3B 4ABDE
- QUIZ 3: The Steps: 1C 2B 3B 4D
- QUIZ 4: The Ropes: 1B 2C 3B 4B
- QUIZ 5: Combination Ladders: 1C 2C 3D 4C
- QUIZ 6: Safe Approach: 1A 2A 3A
- QUIZ 7: Access to Deck: 1BC 2ABCF 3C
- QUIZ 8: Handholds and Stanchions: 1BC 2B 3C 4B
- QUIZ 9: Pilot Ladder Reels: 1B 2C 3C
- QUIZ 10: Inspection and Maintenance: 1A 2BC 3AD